

PMDX-131

4-Axis Breakout/Motherboard for Gecko Stepper Motor Drivers

User's Manual

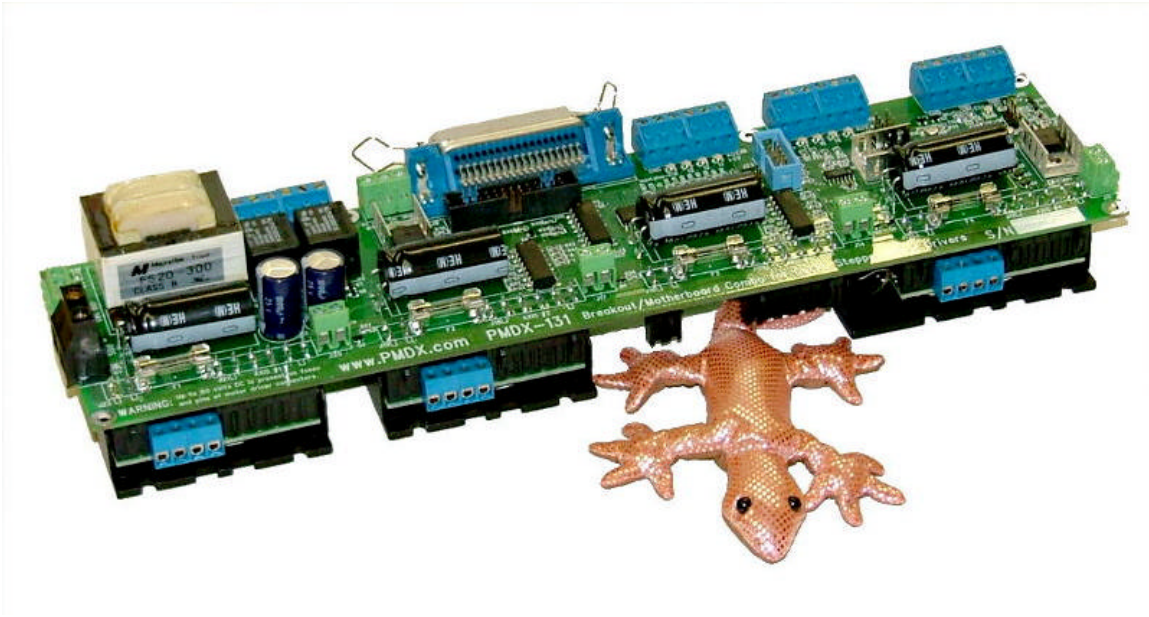

Document Revision: 1.7
Date: 24 July 2007
PCB Revision: PCB-448C through PCB-448E
Serial Numbers: 23231 and above

PMDX
9704-D Gunston Cove Rd
Lorton, VA 22079-2366 USA

Web: <http://www.pmdx.com>
Phone: +1 (703) 372-2975
FAX: +1 (703) 372-2977

1.0 Overview

This document describes the configuration and operation of the PMDX-131 4-Axis Breakout/Motherboard. The PMDX-131 interfaces between the parallel port of an IBM-PC style computer and up to four Gecko stepper driver modules, models G201, G202, G210 and G212.

This document pertains to the following versions of the PMDX-131:

Circuit Board Revision: PCB-448C through PCB-448E (marked on the bottom of the board)
Serial Number Range: 23231 and above

Note that Geckodrive, Inc., the maker of the Gecko stepper motor drives, does not manufacture, sell, or endorse the PMDX-131.

1.1 Important Safety Information

The PMDX-131 is intended for integration by the purchaser into industrial control systems. It is solely the purchaser's responsibility to assure that the system is configured in a manner consistent with applicable safety requirements. Practical Micro Design, Inc. does not control how this board is integrated into the purchaser's system and cannot be responsible for guaranteeing the safety of your system.

The PMDX-131 is not guaranteed to be fail-safe. The system into which the PMDX-131 is installed should provide fail-safe protection and emergency stop capability.

The PMDX-131 contains circuitry that may be connected to dangerous voltages. Care must be taken that user cannot come in contact with these voltages. An enclosure that allows for modest ventilation, but prevents intrusion by operator's hands and foreign objects, especially conductive byproducts of machining operations, should be utilized with this board. Interlock switches on power circuits should remove power when the enclosure is opened.

Automated machine tools, into which the PMDX-131 may be integrated, can cause injury. Precautions should be taken to assure that operators are trained in their proper operation and safety procedures, and that they are protected from moving parts that may be under remote control and may move unexpectedly.

This product may not be used in life support or other critical safety applications.

1.2 Warranty Summary

The PMDX-131 is warranted against failure due to defective parts or workmanship for 90 days from the date of sale. Refer to Appendix A for complete warranty details.

If you have an item requiring service, please see the support page on the PMDX web site (<http://www.pmdx.com>) for return instructions.

The purchaser must pay shipping to return the unit to PMDX. We will ship the repaired unit back to you via ground transportation at our expense. Repairs are normally completed within 10 business days. See Appendix A for our complete warranty details.

1.3 Features

The PMDX-131 has the following features:

PC Parallel Port:

- Buffers signals to/from the PC parallel port
- Allows use of all 8 data bits, 4 control outputs and 5 status inputs
- Centronics cable connector uses standard PC printer cable
- Optional ribbon cable to 25-pin "D" connector

Status Inputs:

- 5 each status inputs w/pull-up resistors
- Status signals are isolated and buffered
- LED indicators for each input

Control Outputs:

- 4 each general purpose digital outputs
- 2 outputs may also drive relays with N.O and N.C. terminals
- Outputs are isolated and buffered
- LED indicator for each output

Gecko Stepper Driver Interface:

- 4 axes of step and direction
- Driver fault sensing
- Buffers signals to drive step & direction inputs
- Wire clamp terminals for the current set resistors

Power Supply Input:

- 120 or 240 VAC input for logic supply
- Separate DC supply input for motor drivers

Special Features:

- Pluggable wire clamp terminal strips for I/O connections from parallel port status and control signals
- Support for Mach2/3 "charge pump"
- Auxiliary +5V supply output
- Power output for optional fan
- Daisy-chain status signal for sharing E-Stop/Charge Pump with PMDX-122 boards

1.4 Updates to this Manual

Check the PMDX web site for revisions or updates to this manual (<http://www.pmdx.com>). The latest revision of this manual is available on the PMDX-131 page (follow the links from the main page).

2.0 Quick Setup Guide

2.1 Package Contents

Each PMDX-131 ships with the following items:

- 1 each PMDX-131 circuit board
- 4 each 4-position plug-on terminal strips (use on the Gecko drive modules, **not** on the PMDX-131)
- 6 each Nylon standoffs, 1-1/4" with 4-40 thread (use to mount the PMDX-131 and Gecko drive assembly to a heat sink plate)

Note that the PMDX-131 ships without plug-on terminal strips for its connectors (J3, J4, J8, J9 and J10). You will be re-using the terminal strips from the Gecko stepper driver modules for the PMDX-131 connectors as described below.

2.2 Assembly steps

1. Remove the pluggable terminal strips from each of the Gecko stepper driver modules (these should be 2 sections of 6-pins each)
2. Install the 6-position terminal strips onto the PMDX-131 connectors J3/J4, J8, J9 and J10. Note that the connectors J3 and J4 are combined into a single 6-position terminal strip.
3. For each Gecko stepper driver module, if they are the G210 or G212 models (or the G201 or G202 with the G901 step multiplier board installed), configure the "Input Option Header" jumpers for "+5VDC common" instead of the default "GROUND common" configuration. The PMDX-131 is

designed to provide a +5VDC common voltage to the Gecko module's opto-isolators. See section 4.9.3 for more information.

4. For each Gecko stepper driver module, plug the 4-pin terminal strip (supplied with the PMDX-131) onto the Gecko module's "Phase A" through "Phase D" terminals.
5. Connect each motor to the 4-pin terminal strips on the Gecko stepper driver module
6. Plug each Gecko stepper driver module onto the connectors on the bottom of the PMDX-131.
7. For each Gecko stepper driver module, install the motor current set resistor in the corresponding 2-pin terminal strip on the PMDX-131. When looking at the PMDX-131/Geckodrive assembly from the edge as shown in Figure 1, this would be the green 2-pin terminal strip above and to the right of each Geckodrive module.
8. Install either (a) an emergency stop switch, or (b) a jumper wire from "E-Stop" to "GND" on connector J10. See section 3.5.2 for more information.
9. The resulting assembly should look similar to Figure 1.

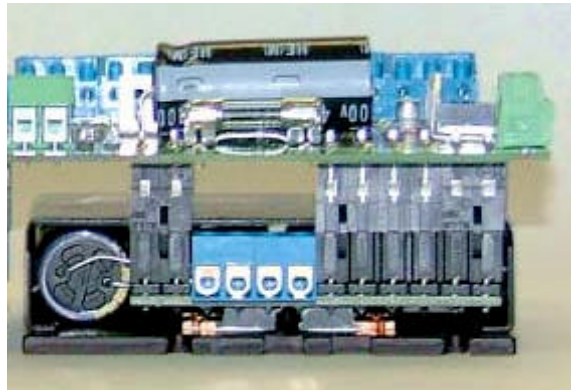

Figure 1 – Sample PMDX-131 and Geckodrive Assembly

2.3 Example Limit Switch Wiring

Mechanical switches, in either "normally open" or "normally closed" configurations, or optical interrupter switches can be used to provide input signals to the PMDX-131. These switches can act as limit switches, home indicators or other status information. Since the PMDX-131 provides pull-up resistors on the status inputs (see section 3.4), mechanical switches can be wired directly to the signal pins on J8 and ground. Note that the examples below show the signals connected to "pin 11" input. The input signals may be connected to any of the signal pins on J8.

Normally Closed Switches

The left-hand drawing in Figure 2 shows an example of "normally closed" mechanical switches. The switches are wired in series so that the "normal" case is ground (logic low) going into pin 11 of the PC's parallel port. When one or more of the switches open, the pull-up resistor on the PMDX-131 provides a logic high into pin 11 on the PC's parallel port. Any number of "normally closed" switches may be connected in series to a single input terminal on the PMDX-131.

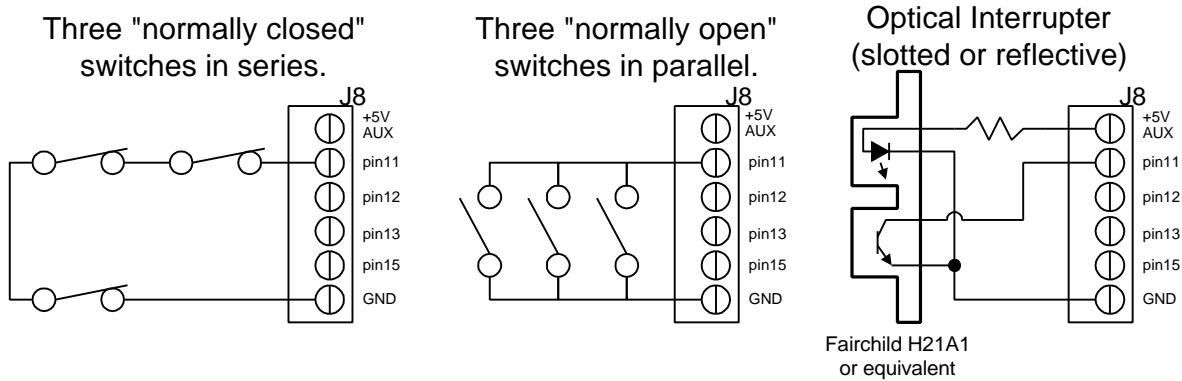

Figure 2 – Example Switch and Optical Interruptor Configurations

Normally Open Switches

The center drawing in Figure 2 shows an example of “normally open” mechanical switches. The switches are wired in parallel so that the “normal” case is +5V (logic high) going into pin 11 of the PC’s parallel port (due to the pull-up resistor on the PMDX-131). When one or more of the switches close, a logic low appears on pin 11 on the PC’s parallel port. Any number of “normally open” switches may be paralleled onto a single input terminal on the PMDX-131.

Optical Interrupter

The right-hand drawing in Figure 2 shows an example of an optical interrupter. This example uses the “+5V Aux Out” from the PMDX-131 to power the sensor. The output signal is connected as an “open collector” output between the PMDX-131 input pin and ground. When light from the LED strikes the sensor, the sensor conducts giving a logic low on pin 11 of the PC’s parallel port. When the LED is “interrupted”, the transistor stops conducting and the PMDX-131’s pull-up resistor gives a logic high on pin 11. The same basic operation applies to the “reflective” version of sensor, i.e. when the light from the LED reflects and strikes the sensor, the sensor outputs a logic “low”.

NOTE: The PMDX-Sensor-S (slotted) and PMDX-Sensor-R (reflective) sensors may be paralleled like “normally open” mechanical switches. They may *not* be wired in series.

2.4 Example Configuration with Daisy-Chained PMDX-122

The PMDX-131 can be connected to a PMDX-122 in a daisy-chain configuration. This allows the PMDX-131’s charge pump, E-Stop and Fault circuitry to enable and disable the PMDX-122’s signals. This configuration also allows the PMDX-122’s E-Stop input to be used as a general-purpose input.

Figure 3 shows a typical daisy-chain configuration. This requires two parallel ports in the PC: one for the PMDX-131 and a second one for the PMDX-122. The PMDX-131 provides power to the PMDX-122 via the unregulated “fan power” output on connector J5. The PMDX-122 is shown connected to two optical encoders, with the data bus direction set to “input to PC”. This is just one example of how the daisy-chained PMDX-122 can be used. Other uses include having the data bus drive Opto-22 relays. Make sure to set the PMDX-122’s jumpers according to your configuration.

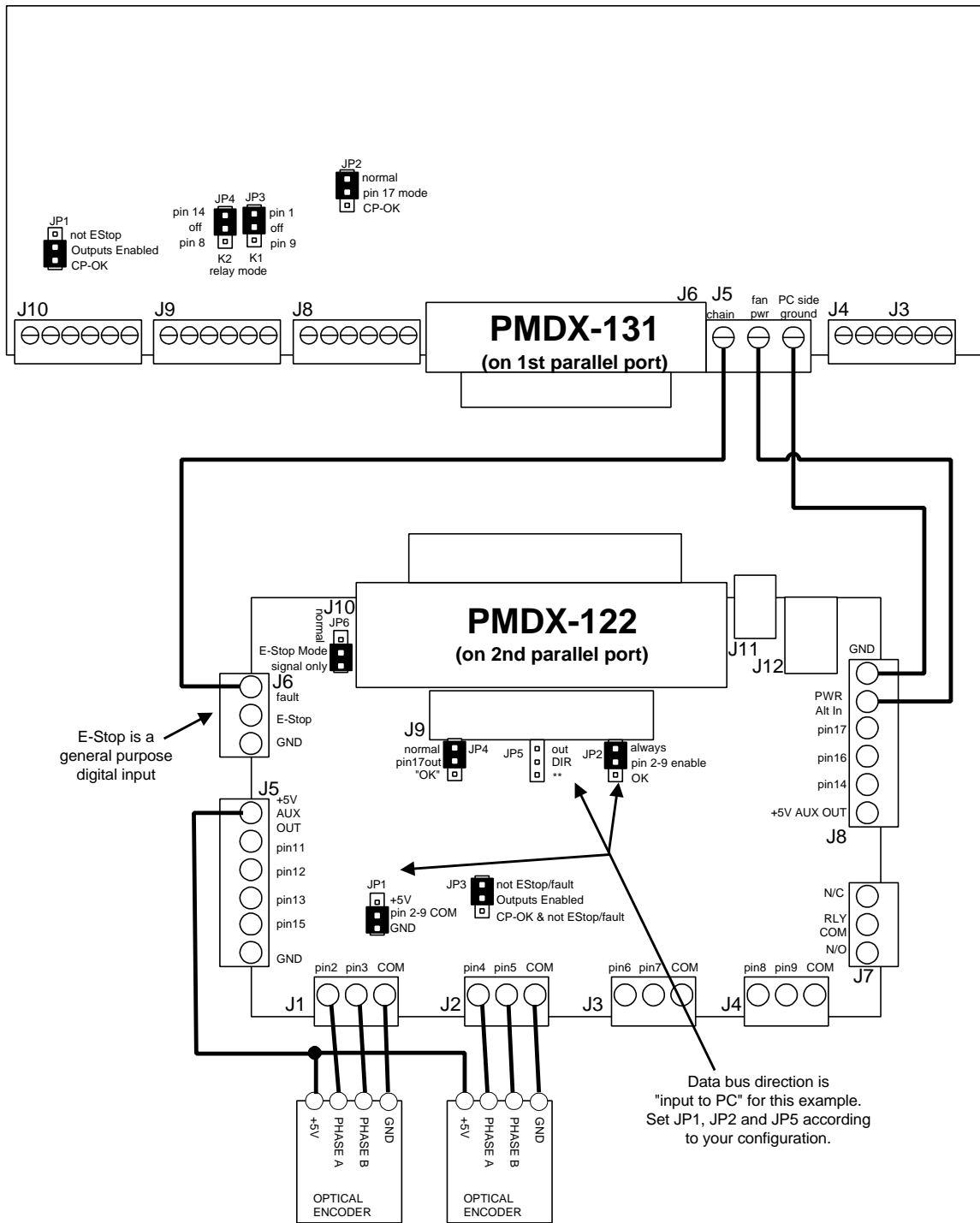

Figure 3 - PMDX-131 with Daisy-Chain PMDX-122

3.0 Functional Description and Block Diagrams

3.1 Data Bus

The PC parallel port contains an 8-bit data bus. The PMDX-131 buffers the data bus signals between the PC and the Gecko stepper drivers. The data bus signals are used as step and direction controls to the stepper drivers as shown in Table 7 on page 16. The output buffers may be disabled via the *Fault*, *E-Stop*, or *Motor Disable* inputs, as well the Gecko stepper driver's "Error" output and, optionally, the charge pump circuit. See sections 3.5 and 3.6 for more information.

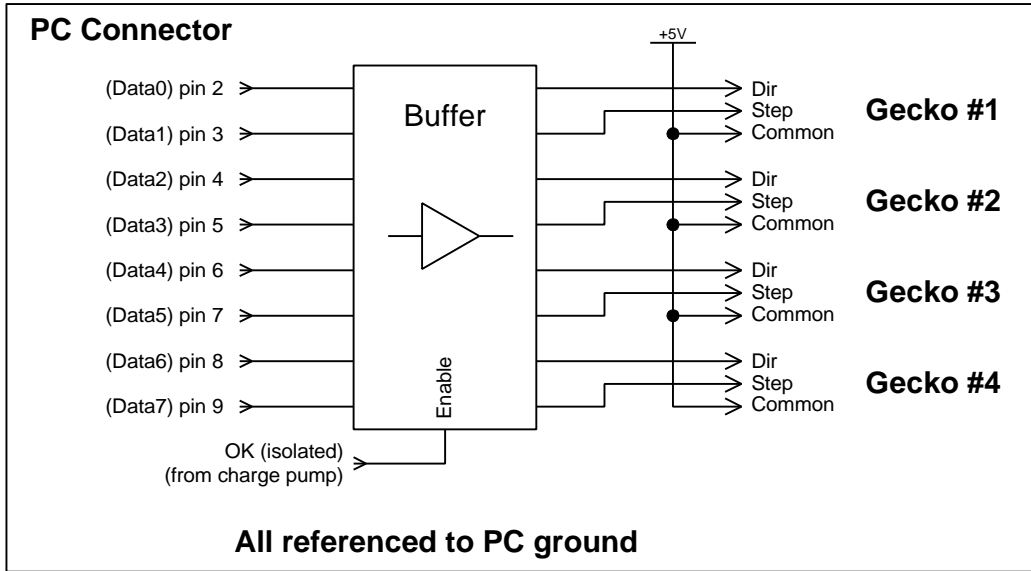

Figure 4 – Block diagram of data bus (step and direction) signals

3.2 Control Outputs

The control signals are isolated and buffered by the PMDX-131. Each control signal output has a 10K ohm pull-down resistor paralleled with an LED. The pull-down resistor provides a default "logic low" when the output buffer is disabled (due to E-Stop, fault, etc.). The LED lights when the output is driven or pulled high. Two of the control signals (pin 1, "*~Strobe*", and pin 14, "*~AutoFeed*") may also drive the two relays. See section 3.3 for more information.

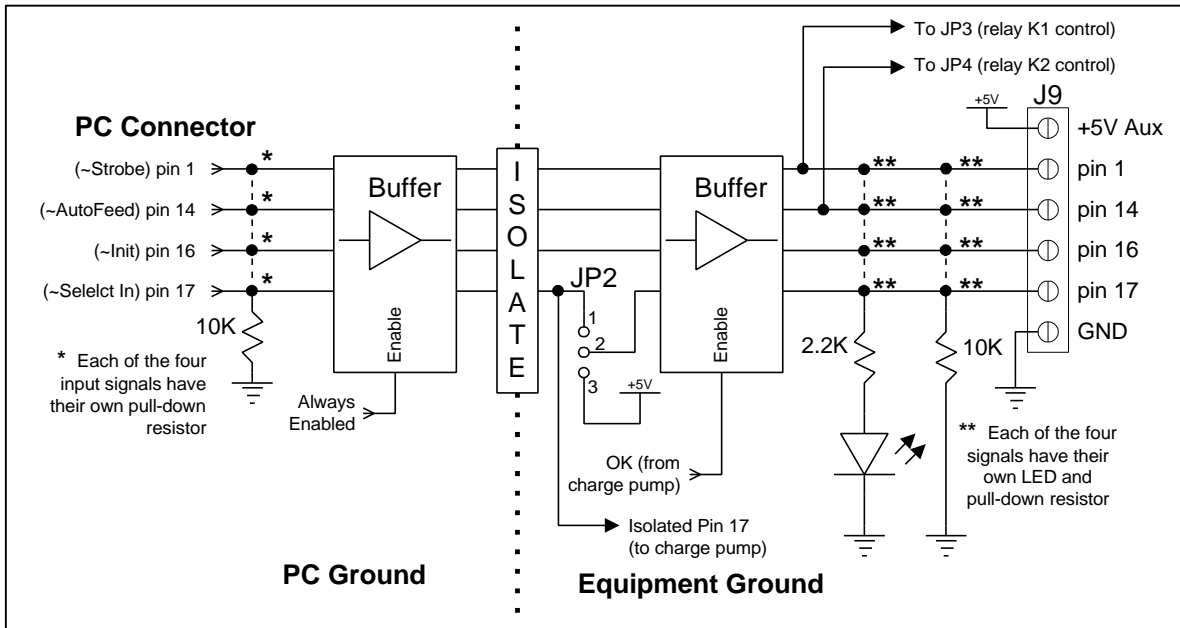

Figure 5 - Block diagram of control signals

3.3 Relay Outputs

Two of the control outputs on the PMDX-131 may drive the on-board relays in addition to being general-purpose outputs (see section 3.2). PC parallel port pin 1 (“~Strobe”) controls relay K1 via jumper JP3, and pin 14 (“~AutoFeed”) controls relay K2 via jumper JP4. These two jumpers allow the relays to be disabled when their control outputs are used as “logic only” outputs. The block diagram below shows the block diagram of one of the relay circuits. The other circuit is identical but uses the second set of reference designators. See section 5.3 for more information on the jumper settings.

Each relay driver circuit has its own LED (in addition to the LED on the control output section as described in section 3.2). The relay LED lights when the relay is energized (i.e. the “COM” terminal is connected to the “N/O” terminal).

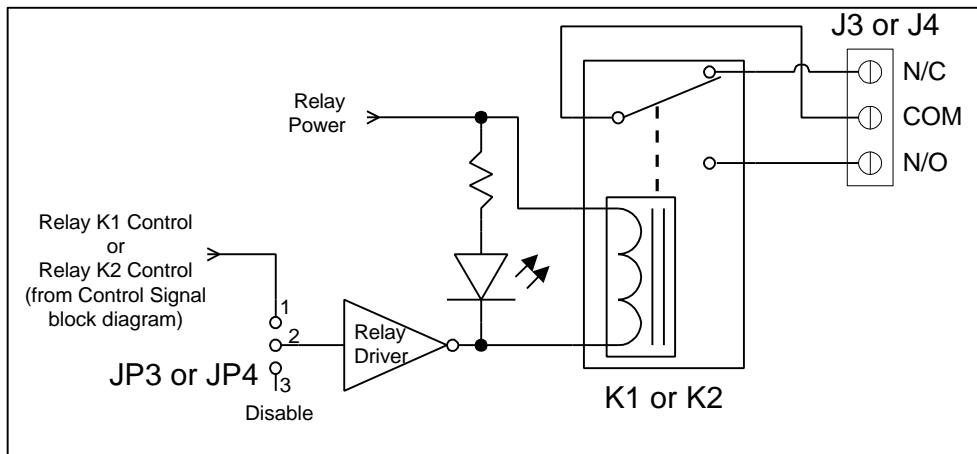

Figure 6 - Block diagram of relay output signals

3.4 Status Inputs

Four of the status signals are available as general-purpose inputs: pins 11, 12, 13 and 15. The fifth status input on the PC parallel port (pin 10, *~Ack*) is connected to the *Fault* and *E-Stop* circuitry. See section 3.5, for more information on this signal. Figure 7 shows a block diagram of the status input circuitry.

The "Status Input" LEDs are located next to connector J8, just above each of the pin number labels ("pin 11", "pin 12", "pin 13" and "pin 15"). Each LED is "on" when the corresponding input signal is driven low.

The status signals are isolated and buffered by the PMDX-131. Each status input has a 2.2K ohm pull-up resistor in series with an LED. The pull-up resistor provides a default "logic high" when the input is not connected, and also allows the input to be connected to open-collector drivers or mechanical switches to ground. The LED lights when the input signal is driven low. The optical isolators further act as a low-pass filter to remove high-frequency noise from the inputs.

NOTE – Due to logic inside the PC, some status inputs are inverted. This means that a logic "high" output from the PMDX-131 to the PC's parallel port is read as a "0" in the status register. Please refer to technical documentation on the PC parallel port or your control software for more information.

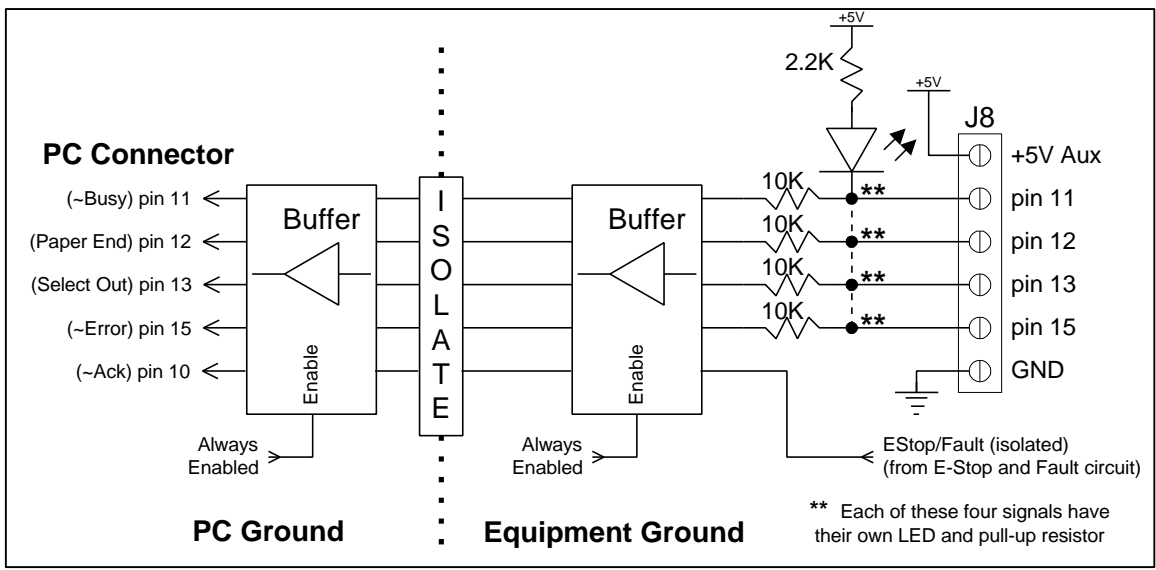

Figure 7 – Block diagram of status signals

3.5 Fault, E-Stop and Motor Disable

The *Fault*, *E-Stop* and *Motor Disable* inputs, along with the Gecko stepper driver's "Error" signals, provide ways for external circuitry and the Gecko drivers to enable and disable the operation of the PMDX-131. The following table summarizes the effects of these signals, as well as the charge pump (see section 3.6). Figure 8 shows a block diagram of the Fault, E-Stop and Motor Disable circuitry.

Condition (signal asserted)	Step/Dir Outputs	Control Outputs	~ACK status (to PC)	Motor Current (see section 3.5.3)
E-Stop	Disabled (tri-state)	Disabled (pull-down resistor)	Logic High	Enabled
Fault	Disabled (tri-state)	Disabled (pull-down resistor)	Logic High	Enabled
Gecko Stepper Driver "Error" Signal	Disabled (tri-state)	Disabled (pull-down resistor)	Logic High	Enabled
Motor Disable	Disabled (tri-state)	Disabled (pull-down resistor)	Logic High	Disabled
Charge Pump Failure (only when jumper JP1 is set to "CP-OK")	Disabled (tri-state)	Disabled (pull-down resistor)	Logic Low	Enabled

Table 1 – Summary of effects from fault sources

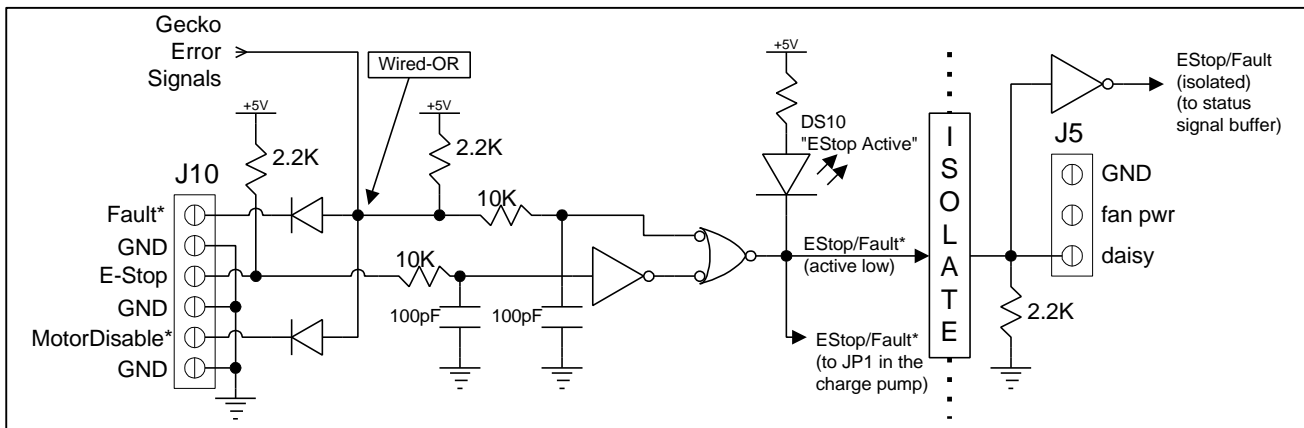

Figure 8 – Block diagram of E-Stop, Fault and Motor Diable signals

3.5.1 Fault Input

The *Fault* input provides an interface for external fault detection circuits. This signal is "active low", meaning that a logic "low" indicates a fault condition, and a logic high (or floating) means "all is OK". Figure 8 shows block diagrams of the *Fault* input circuitry, and Table 1 on page 11 shows the effects of the *Fault* signal.

The *Fault* input can be connected to an external "wired-or" configuration of open-collector status signals or mechanical switches to ground (switch closed means "fault"). All of the external fault signals should be tied together and connected to the PMDX-131's *Fault* input. The *Fault* input has a 2.2K ohm pull-up resistor, so the input may be left unconnected when not used. To indicate a fault condition, drive this input to ground (via either open-collector or TTL-style drivers or mechanical switches).

Some Gecko stepper drivers implement a "fault output" on pin 7. This signal is "wire OR-ed" with the PMDX-131's *Fault* signal so that the Gecko stepper drivers may also signal a fault condition on the PMDX-131.

NOTE – The PMDX-131's *Fault* signal **must** be either driven high (+5V) or allowed to float in order for the motor driver's step inputs to be enabled and the "~Ack" status signal to the PC parallel port to go low (signaling "OK"). If you do not have any fault detection circuitry, leave the *Fault* input unconnected.

3.5.2 E-Stop Input

The *E-Stop* input provides an interface for external "emergency stop" circuits (see Figure 8 on page 11). This signal is "active high", such that a logic "high" tells the system to stop, and a logic low means "all is OK". The *E-Stop* input has a 2.2 Kohm pull-up resistor so that the default condition is "E-Stop".

The *E-Stop* input should be connected to an external "normally closed" switch (or group of switches all wired in series). The external switch(es) should be wired between the *E-Stop* pin and ground, such that the switch contacts open to signal an emergency stop condition. If this input is not used, it must be jumpered to ground. The PMDX-131 provides a 2.2K ohm pull-up resistor on the *E-Stop* input. This means that the external emergency stop circuit must be capable of sinking 2.7 mA of current when the switch contacts are "closed".

The *E-Stop*, *Fault* and *Motor Disable* inputs are combined (logic "OR") with the "Error" signal from the Gecko stepper drivers to drive the "~Ack" status signal to the PC's parallel port and to enable or disable the data bus and control output buffers.

NOTE – The *E-Stop* signal **must** be grounded (or driven low) in order for the data bus and control output buffers to be enabled, and for the "~Ack" status signal to the PC parallel port to go low.

When any or all of the *E-Stop* (active high), *Fault* (active low), *Motor Disable* (active low) inputs, or any of the Gecko driver's "error" outputs are asserted, the following actions take place:

- The ACK bit in the PC's status register reads as a "1" (to indicate "E-Stop")
- The LED labeled "Outputs Enabled" (reference designator DS12, along the right-hand edge of the board) is "off"
- The *Fault* daisy-chain output on J5 is tri-stated with a weak (10K ohm) pull-down
- The control outputs are tri-stated with a weak (10K ohm) pull-down
- The relays are de-energized
- The data bus outputs to the Gecko stepper drivers are tri-stated

3.5.3 Motor Disable Input

The Motor Disable input allows external circuitry to place the stepper motors into a "minimum torque" condition. It does so by overriding the "current set" resistors and setting the motor current to "near" zero. The amount of holding torque while "disabled" will depend on the motors used. This "disable" function allows for manual operation of the motors by removing most, but not all of the motor torque. An emergency stop condition is also signaled when Motor Disable occurs. This disables the step and direction outputs and any controls (such as spindle power) normally turned on by the outputs. Any controls that need to operate while in "manual" mode must have a manual override.

This input is active low and has a 2.2 Kohm pull-up resistor so that it may be left unconnected when not used. To disable the motor drivers, drive this input to ground via open-collector or TTL style drivers or mechanical switches.

NOTE – The Motor Disable signal **must** be either driven high (+5V) or allowed to float in order for the motor driver's step inputs to be enabled and the "~Ack" status signal to the PC parallel port to go low (signaling "OK"). If you do not have any motor disable circuitry, leave this input unconnected.

3.6 Charge Pump (watchdog)

The charge pump circuit (also called a watchdog circuit) is designed to disable the PMDX-131 and all stepper motor drivers when the software running on the PC stops working properly. The charge pump

also keeps the PMDX-131 disabled while the PC starts up (i.e. all outputs are disabled until the PC boots and the CAD/CAM application software is running). It does this by monitoring pin 17 on the PC parallel port (the “~Select In” signal). When this signal is toggling between high and low, the charge pump is “OK”. When the “~Select In” signal stops toggling, the charge pump is “not OK”. Jumper JP1 determines whether the output from the charge pump is used to enable and disable the control and data bus output buffers (see section 5.1). See Table 1 on page 11 for a summary of the effects of the charge pump circuit.

This charge pump circuit is designed to work with the Mach2/3 CNC software. However, any software that can toggle pin 17 on the PC parallel port can make use of this feature. If your software does not support this feature, configure jumper JP1 to disable the charge pump circuit (see section 5.1). See section 7.0, *Electrical and Environmental Specifications*, for information on minimum charge pump frequency.

NOTE – The state of the charge pump signal is **not** reflected in the *E-Stop* and *Fault* status that is output on the “~Ack” signal to the PC (pin 10 on the parallel port). This is to prevent “lock up” of the software. Mach2/3 CNC software requires that the Emergency Stop signal (~Ack) **not** be asserted before it will start generating the “charge pump” signal.

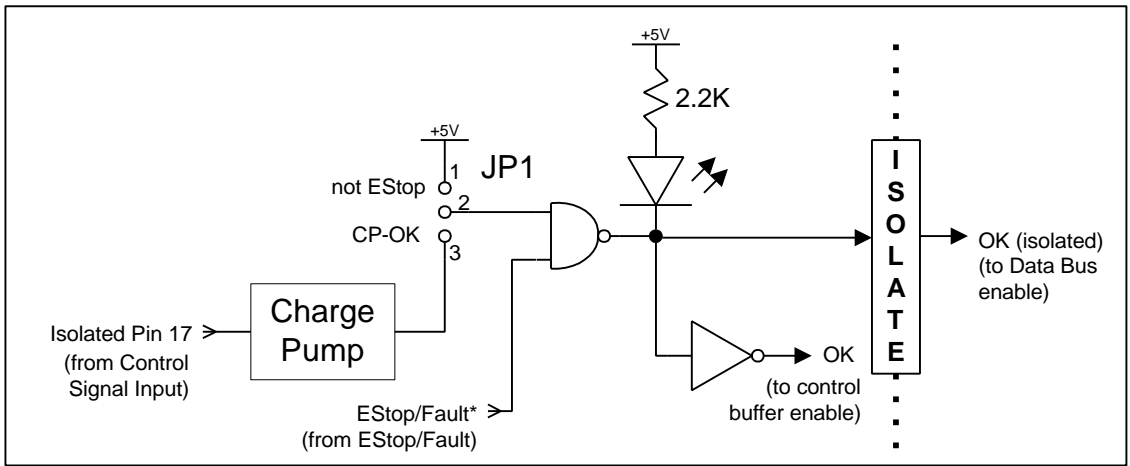

Figure 9 – Block Diagram of Charge Pump signals

4.0 Connectors

The PMDX-131 contains the following connectors. Refer to the following sections for details on the pin-outs for each connector. For all connectors, pin “1” is the pin closest to the reference designator (i.e. J1 pin 1 is the pin closest to the “J1” text on the circuit board). In addition, all connectors have square pads on pin 1 (look on the bottom of the circuit board).

Connector	Description
J1	DC power supply input for stepper drivers
J2	AC power for logic supply
J3 & J4	Relay contact connections
J5	Fan power output and daisy-chain signal
J6	Centronics 36-pin PC Parallel Port
J7	26-pin ribbon header (alternate connection to PC parallel port)
J8	Status input connections
J9	Control output connections
J10	Fault, E-Stop and Motor Disable connections
J11, J14, J17 & J20	Current set resistor connections for four Gecko stepper drivers
J12 & J13	Connections to Gecko stepper driver #4 (on the bottom of the board)
J15 & J16	Connections to Gecko stepper driver #3 (on the bottom of the board)
J18 & J19	Connections to Gecko stepper driver #2 (on the bottom of the board)
J21 & J22	Connections to Gecko stepper driver #1 (on the bottom of the board)
J23	Reserved for future use

Table 2 - Summary of PMDX-131 Connectors

4.1 DC (Motor) Power Supply (J1)

J1 is a two-position wire clamp screw terminal for the DC power supply input. This power input is used solely as the motor power for the Gecko stepper driver modules. An LED (DS11) next to the connector lights to indicate the presence of DC power.

Pin Number	Label	Description
1	POS	Positive DC input terminal
2	NEG	Negative DC input terminal (does <i>not</i> have to be the same as the PC's ground reference)

Table 3 – DC Power Connector Pin-Out (J1)

WARNING: *The voltage connected to the motor power input must conform with the Gecko stepper driver specifications. Do not exceed 80 volts DC at the motor power input to the PMDX-131 board.*

The power to each driver is fused and equipped with a 470 uF, 100 volt power filtering capacitor as recommended by Geckodrive. When using the Geckodrive G202 or G212, the PMDX-131's capacitor is redundant, but not harmful.

The PMDX-131 comes equipped with 5 ampere fast blow fuses. You may replace them with fuses for less current, but do not increase above 5 amperes, even if the Gecko stepper drivers are set for currents above 5 amperes. The Gecko stepper drivers will draw less than 5 amperes even when providing 7 amperes to the motors. These fuses are 5mm x 20mm fuses rated for 125 volts minimum.

4.2 AC Power Supply (J2)

J2 is a 3-position wire clamp screw terminal for AC power input. It allows the use of either 120 VAC or 240 VAC mains voltage. This power supply input provides power to everything **except** the stepper motor drivers (see section 4.1). An LED next to the connector (DS5) lights to indicate the presence of regulated +5V DC derived from this AC power supply. Note that this LED may glow dimly if AC power is removed and the board is connected to the PC's parallel port, however, the PMDX-131 will not function correctly unless AC power is supplied.

The PMDX-131 provides its own isolated power for the status inputs (see sections 3.4 and 4.6) and control outputs (see sections 3.2 and 4.7). Therefore, the AC power supply does not require an external isolation transformer.

Pin Number	Label	Description
1	0V	Connection for AC mains NEUTRAL input
2	120 VAC	Input for use with 120 VAC mains (leave as a "no connect" for 240 VAC mains)
3	240 VAC	Input for use with 240 VAC mains (leave as a "no connect" for 120 VAC mains)

Table 4 – AC Power Connector Pin-Out (J2)

4.3 Relay Contact Connectors (J3 & J4)

J3 and J4 provide connections to the output relay contacts. These contact ratings are specified in section 7.0. These relays may be controlled by two of the control signals, or they may be disabled, depending on the configuration of jumpers JP3 and JP4 (see section 5.3).

Pin Number	Label	Description
1	N/O	Normally open contact
2	COM	Common center pole
3	N/C	Normally closed contact

Table 5 – Relay Contact Connector Pin-Out (J3 and J4)

4.4 Unregulated Power and Daisy-Chain Output (J5)

The PMDX-131 provides an unregulated 12 to 16 volt DC power output on J5. This output can be used to power a fan (24 volt fan running "under speed" is recommended), or to power a companion PMDX-122 board. Note that this power output (and therefore any connected PMDX-122 boards) share ground with the PC side of the interface isolation barrier.

Pin Number	Label	Description
1	chain	Fault signal output, used to daisy-chain to a PMDX-122
2	fan pwr	Unregulated power output for fan or PMDX-122
3	PC side ground	Ground reference on PC side of the isolation barrier

Table 6 – Unregulated Power and Daisy-Chain Connector Pin-Out (J5)

4.5 PC Parallel Port (J6 & J7)

The PMDX-131 provides a Centronics-style connector (J6) for connections to a PC's parallel port. This allows the use of a standard PC printer cable. The board also provides a 26-pin ribbon cable header (J7). This header allows the use of a "ribbon cable to 25-pin "D" connector" adapter cable as an alternative to the standard PC printer cable and the Centronics connector.

NOTE – Some printer cables do not have good signal shielding. Some cables also omit some of the status or control signals (such as “~Auto Feed” and “Select Out”, 25-pin “D” connector pin numbers 14 and 13, respectively). We recommend using cables that are listed as IEEE-1284 compliant.

PC (note 1)	Pin Numbers		PC Signal Name	Direction (relative to the PC)	PMDX-131 Signal	Comment
	J6 (note 2)	J7 (note 3)				
1	1	1	~Strobe	out	Output “pin 1” and relay K1 control	Isolated and buffered output
2	2	3	Data 0	out	Dir signal to Gecko #1	Buffered signals from the PC.
3	3	5	Data 1	out	Step signal to Gecko #1	
4	4	7	Data 2	out	Dir signal to Gecko #2	
5	5	9	Data 3	out	Step signal to Gecko #2	
6	6	11	Data 4	out	Dir signal to Gecko #3	
7	7	13	Data 5	out	Step signal to Gecko #3	
8	8	15	Data 6	out	Dir signal to Gecko #4	
9	9	17	Data 7	out	Step signal to Gecko #4	
10	10	19	~Ack	in	E-Stop, Fault and Motor Disable	
11	11	21	Busy	in	Contact Closure “pin 11”	Isolated and buffered signals into PC, with internal pull-up resistors allowing them to directly sense switch closures to ground (pin 6 of J8).
12	12	23	Paper End	in	Contact Closure “pin 12”	
13	13	25	Select Out (note 4)	in	Contact Closure “pin 13”	
14	14	2	~Auto Feed	out	Output “pin 14” and relay K2 control	Isolated and buffered output
15	32	4	~Error	in	Contact Closure “pin 15”	See contact closure note above
16	31	6	~Init	out	Output “pin 16”	Isolated and buffered output
17	36	8	~Select In (note 4)	out	Output “pin 17” and charge pump signal	Isolated and buffered output, see section 3.6 for charge pump description.
18 – 25	19-30, 33	10-24 (even)	Ground		Ground	

Table 7- PC Parallel Port Connectors (J6 and J7)

NOTE 1 – The PC Pin number column lists the pin numbers as they would appear on the PC’s 25-pin “D” connector when using a standard printer cable.

NOTE 2 – J6 is the Centronics 36-pin connector on the PMDX-131. Only the Centronics pins listed in the table above are connected to the PMDX-131. All other pins on the Centronics connector are not connected to the PMDX-131.

NOTE 3 – J7 is the 26-pin ribbon cable header on the PMDX-131.

NOTE 4 – The “~Select In” and “Select Out” signals are named relative to the printer’s point of view. That is why the “~Select In” is an *output* from the PC, and “Select Out” in an *input*.

The following web sites provide information regarding the PC's parallel port, including pin-outs, signal names and useful data for software control of the parallel port:

- IBM PC Parallel Port FAQ and tutorial
<http://www.pmdx.com/Resources/parallel-port.html>
 and
<http://et.nmsu.edu/~etti/fall96/computer/printer/printer.html>
- General information and lots of links
<http://www.lvr.com/parport.htm>
- If the previous links do not work, go to <http://www.pmdx.com> (our main web page), click on the "handy CNC information" link and then look for the links to parallel port information pages

Note that these web links were accurate as of the printing date of this manual. While we expect that these two sites will remain available at these addresses, it is possible that they will move or disappear.

4.6 Status Input Connector (J8)

The status input connector provides wire clamp screw terminal connections for all of the PC parallel port status signals except the "~Ack" signal (pin 10 of the parallel port). The "~Ack" signal is used to indicate emergency stop and fault conditions to the PC. See section 3.5.2 for more information on the emergency stop input and the "~Ack" signal.

Pin Number	Label	Description
1	AUX +5V	Auxiliary regulated +5V output (referenced to the isolated ground provided on pin6 of this connector)
2	11	Status input to PC parallel port pin 11 (Busy)
3	12	Status input to PC parallel port pin 12 (Paper End)
4	13	Status input to PC parallel port pin 13 (Select Out)
5	15	Status input to PC parallel port pin 15 (~Error)
6	GND	Ground (isolated from the PC's ground)

Table 8 – Status Input Connector Pin-Out (J8)

4.7 Control Output Connector (J9)

The control output connector provides wire clamp screw terminal connections for all of the PC parallel port control signals.

Pin Number	Label	Description
1	AUX +5V	Auxiliary regulated +5V output (referenced to the isolated ground provided on pin6 of this connector)
2	1	Control output from PC parallel port pin 1 (~Strobe)
3	14	Control output from PC parallel port pin 14 (~Auto Feed)
4	16	Control output from PC parallel port pin 16 (~Init)
5	17	Control output from PC parallel port pin 17 (~Select In – the signal that also feeds the PMDX-131's charge pump circuit, see section 3.6).
6	GND	Ground (isolated from the PC's ground)

Table 9 – Control Output Connector Pin-Out (J9)

4.8 Fault, E-Stop and Motor Disable Connector (J10)

This connector provides wire clamp screw terminal connections for external E-Stop, Fault, and Motor Disable functions (see section 3.5).

Pin Number	Label	Description
1	Fault*	Fault input (active low)
2	GND	Ground (isolated from the PC's ground)
3	Estop	Emergency Stop input (active high)
4	GND	Ground (isolated from the PC's ground)
5	MtrDis*	Motor Disable input (active low)
6	GND	Ground (isolated from the PC's ground)

Table 10 – Control Output Connector Pin-Out (J10)

4.9 Motor Driver Connectors (J11 through J22)

These connectors provide for up to four Gecko Stepper Driver modules. Gecko stepper drivers may be installed on these sets of connectors in any combination. The only restriction is that the step and direction signals from the PC's parallel port are hard wired to specific connectors, as shown in Table 7 on page 16.

Driver Number	Motor Power	Control Signals	Motor Current Set
Gecko #1	J22	J21	J20
Gecko #2	J19	J18	J17
Gecko #3	J16	J15	J14
Gecko #4	J13	J12	J11

Table 11 – Motor Driver Connector Groupings

PMDX-131 Pin Number	Gecko Pin Number	Description
1	1	Motor Ground (negative connection)
2	2	Motor Power (positive connection)

Table 12 – Motor Power Connector Pin-Out (J13, J16, J19 & J22)

PMDX-131 Pin Number	Gecko Pin Number	Description
1	7	Disable/Error (varies with Gecko model)
2	8	Direction
3	9	Step
4	10	+5V common for opto-couplers on the Gecko drivers
5	11	Rset (current setting resistor)
6	12	Rset Gnd (current setting resistor)

Table 13 – Motor Control Signal Connector Pin-Out (J12, J15, J18, and J21)

Pins 3, 4, 5 and 6 of the Gecko stepper motor drivers are wired directly to the motor via a pluggable terminal strip and do not pass through the PMDX-131 board.

4.9.1 Error Signal

This is the error output signal from some of the Gecko stepper drivers (i.e. the G204V). Some stepper driver also use this signal as a motor disable input. The PMDX-131 uses this signal only as an "error input". The PMDX-131 does **not** use this signal to disable the motor current (see section 3.5.3). If one driver faults the other drivers will still have motor current, but will be inhibited from stepping.

4.9.2 Step & Direction Signals

The step and direction signals are hard-wired to specific motor driver connectors (see Table 7 on page 16). These signals are buffered on the PMDX-131. However, they are **not** optically isolated by the PMDX-131 because the Gecko stepper driver modules have optical isolation on the step and direction inputs.

4.9.3 +5V Common

The PMDX-131 provides +5 volts for the Gecko step and direction opto-couplers. Your Gecko stepper drivers should be jumpered for +5VDC common if equipped with a jumper. The Gecko 201 and 202 drives do not have such a jumper and are always configured for +5VDC common, unless they have the G901 option board installed (which provides a step multiply function).

4.9.4 Rset Signals

These signals are used to connect a current setting (programming) resistor to the Gecko stepper motor drivers. The resistors are mounted on the PMDX-131 board and internally connected to these terminals on the Gecko stepper drivers.

4.10 PMDX Proprietary Connector (J23)

Reserved for use with PMDX accessories.

5.0 Jumpers

The PMDX-131 contains four 3-pin jumpers that determine various aspects of its behavior. Each jumper has silk screen labels that describe the function of the jumper, and each possible setting. Each jumper should have a shorting block installed either between pins 1 and 2, between pins 2 and 3, or on some jumpers the shorting block can be removed. Figure 10 shows the location of all of the jumpers on the PMDX-131.

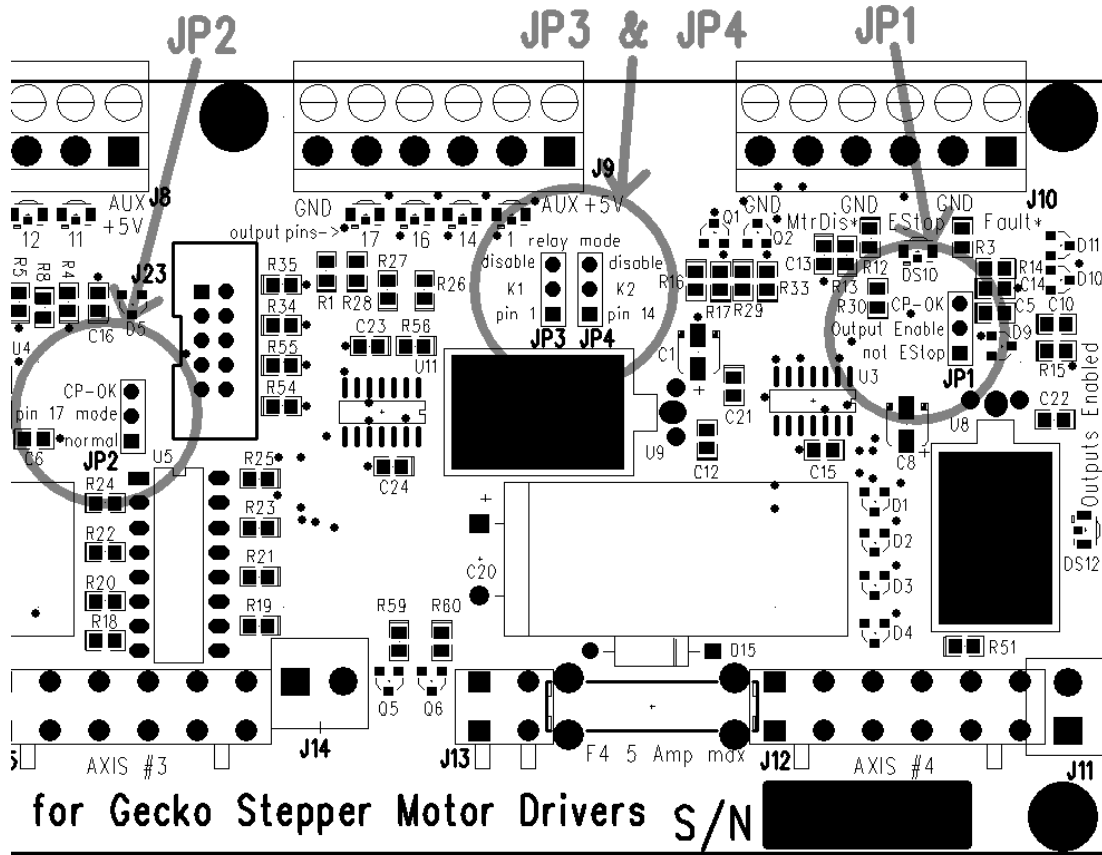

Figure 10 –Jumper Locations

5.1 Output Enable (JP1)

This jumper determines when the PMDX-131 outputs are enabled. This controls all of the outputs: step and direction (i.e. data bus) and control signals. Figure 10 on page 20 shows the location of this jumper.

Setting	Label	Description
1 to 2	not Estop	Outputs will be enabled whenever an emergency stop or fault condition does not exist. The “charge pump” is ignored.
2 to 3	CP-OK	Outputs will be enable when “charge pump” is in the OK condition <i>AND</i> no emergency stop or fault condition exists.

Table 14 – “Output Enable” Jumper Settings (JP1)

5.2 Pin 17 Mode (JP2)

This jumper selects which signal is presented on the “pin 17” terminal on connector J9. Figure 10 on page 20 shows the location of this jumper.

Setting	Label	Description
1 to 2	normal	Pin 17 from the PC parallel port drives the "pin 17" control output on J9 as well as the charge pump circuitry.
2 to 3	CP-OK	Pin 17 from the PC parallel port drives only the charge pump circuitry. The "pin 17" control output on J9 is driven "high" or floats low based on the state of the <i>E-Stop</i> , <i>Fault</i> and <i>Motor Disable</i> inputs, the Gecko stepper driver "Error" signals, and optionally depending on jumper JP1, the "charge pump" circuit.. See sections 3.5, and 3.6 for more information. This setting allows the charge pump circuit to disable external drivers via opto-isolated relays, or can be used to daisy-chain the PMDX-131 to a PMDX-122 boards (see section 2.4).

Table 15 – "Pin 17 Mode" Jumper Settings (JP2)

5.3 Relay Mode (JP3 and JP4)

These jumpers select whether the PC parallel port signals control the two relays or the relays are not used. Figure 10 on page 20 shows the location of these jumpers.

Setting	Label	Description
1 to 2	pin 1	Relay controlled from PC parallel port pin 1 (~Strobe status signal)
2 to 3	disable	Relay is not driven (this silences the relay when J9 pin 1 is used as a digital output)

Table 16 – "K1 Relay Mode" Jumper Settings (JP3)

Setting	Label	Description
1 to 2	pin 14	Relay controlled from PC parallel port pin 14 (~AutoFeed status signal)
2 to 3	disable	Relay is not driven (this silences the relay when J9 pin 14 is used as a digital output)

Table 17 – "K2 Relay Mode" Jumper Settings (JP4)

6.0 Mechanical Specifications

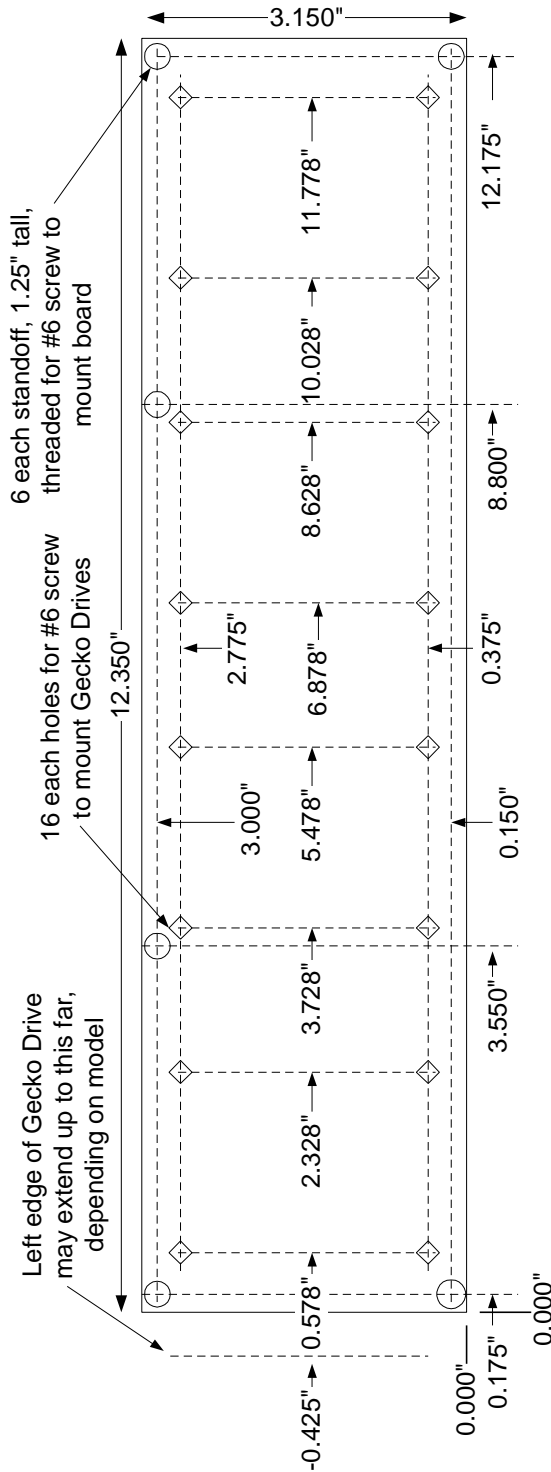

The height between the bottom of the Gecko drivers and the bottom of the PMDX-131 circuit board is 1.25". This allows mounting the circuit board on standard 1.25" tall by 0.25" diameter standoffs. The mounting holes in the PMDX-131 are designed to accommodate #6 screws.

The datum for all measurements is at (0,0) on the diagram.

The maximum component height above the PMDX-131 circuit board is 1.400" for the transformer.

NOTE: These mechanical dimensions must be accurately followed so that the connectors on the PMDX-131 will mate properly with the terminal block pins of the Gecko stepper motor drivers.

WARNING: *The PMDX-131 should be protected from liquids, dirt, or chips (especially metal chips which can cause shorts) coming in contact with the board.*

Figure 11 - PMDX-131 Dimensions and Mounting Plate Holes

Appendix A – Warranty

Statement

Practical Micro Design, Inc. (PMD) warrants that this hardware product is in good working condition, according to its specifications at the time of shipment, for a period of 90 days from the date it was shipped from PMD. Should the product, in PMD's opinion, malfunction within the warranty period, PMD will repair or replace the product without charge. Any replaced parts become the property of PMD. This warranty does not apply to the software component of a product or to a product which has been damaged due to accident, misuse, abuse, improper installation, usage not in accordance with product specifications and instructions, natural or personal disaster or unauthorized alterations, repairs or modifications.

Limitations

All warranties for this product, expressed or implied, are limited to 90 days from the date of purchase and no warranties, expressed or implied, will apply after that period.

All warranties for this product, expressed or implied, shall extend only to the original purchaser.

The liability of Practical Micro Design, Inc. in respect of any defective product will be limited to the repair or replacement of such product. Practical Micro Design, Inc. may use new or equivalent to new replacement parts.

Practical Micro Design, Inc. makes no other representations or warranties as to fitness for purpose, merchantability or otherwise in respect of the product. No other representations, warranties or conditions, shall be implied by statute or otherwise.

In no event shall Practical Micro Design, Inc. be responsible or liable for any damages arising

- (a) from the use of the product;
- (b) from the loss of use of the product;
- (c) from the loss of revenue or profit resulting from the use of the product; or
- (d) as a result of any event, circumstance, action or abuse beyond the control of Practical Micro Design, Inc.

whether such damages be direct, indirect, consequential, special or otherwise and whether such damages are incurred by the person to whom this warranty extends or a third party.