

# PMDX-105 Quad Isolator Board

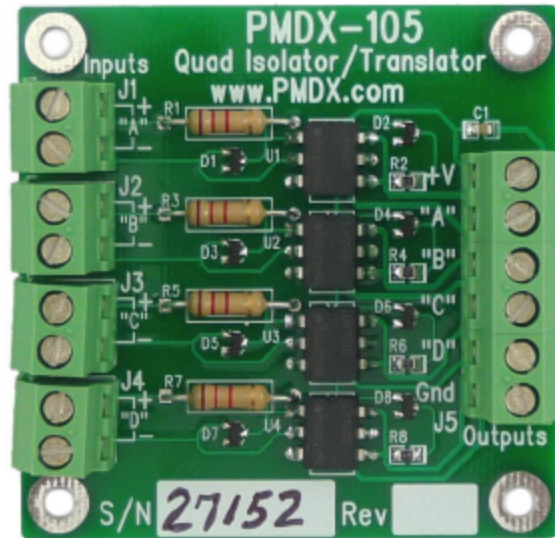

## PRELIMINARY User's Manual

Please see our website  
for an updated manual

Document Revision: 0.3  
Date: 22 June 2010

PMDX  
9704-D Gunston Cove Rd  
Lorton, VA 22079-2366 USA

Web: <http://www.pmdx.com>  
Phone: +1 (703) 372-2975  
FAX: +1 (703) 372-2977

# Table of Contents

---

<b>1.0</b>	<b>Overview</b> .....	<b>3</b>
1.1	Important Safety Information .....	3
1.2	Warranty Summary .....	3
1.3	Features.....	4
1.4	Updates to this Manual .....	4
<b>2.0</b>	<b>Installation and Operation</b> .....	<b>4</b>
2.1	Connecting to PMDX-125 Inputs .....	5
2.2	Connecting to PMDX-122 Inputs .....	5
2.3	Connecting to PMDX-132 Inputs .....	6
2.4	Connecting To and Powering PNP Proximity Sensors.....	6
2.5	Connecting Between Breakout Board Outputs and PLC Inputs .....	8
2.6	Connecting to a Generic Breakout Board.....	8
<b>3.0</b>	<b>Mechanical Specifications</b> .....	<b>9</b>
<b>4.0</b>	<b>Electrical and Environmental Specifications</b> .....	<b>9</b>
	<b>Appendix A – Warranty</b> .....	<b>10</b>

**PRELIMINARY**

# PMDX-105 Quad Isolator Board User's Manual

Document Revision: 0.3

---

## 1.0 Overview

This document describes the configuration and operation of the PMDX-105 Quad Isolator Board. The PMDX-105 Quad Isolator Board is useful for providing low-speed isolated control signals up to 24 volts into or out of a breakout board.

### 1.1 Important Safety Information

The PMDX-105 Quad Isolator Board is intended for integration by the purchaser into industrial control systems. It is solely the purchaser's responsibility to assure that the system is configured in a manner consistent with applicable safety requirements. Practical Micro Design, Inc. does not control how these parts are integrated into the purchaser's system and cannot be responsible for guaranteeing the safety of your system.

The PMDX-105 Quad Isolator Board is not guaranteed to be fail-safe. The system into which the PMDX-105 Quad Isolator Board is installed should provide fail-safe protection and emergency stop capability.

Automated machine tools, into which the PMDX-105 Quad Isolator Board may be integrated, can cause injury. Precautions should be taken to assure that operators are trained in their proper operation and safety procedures, and that they are protected from moving parts that may be under remote control and may move unexpectedly.

This product may not be used in life support or other critical safety applications.

### 1.2 Warranty Summary

The PMDX-105 Quad Isolator Board is warranted against failure due to defective parts or workmanship for 90 days from the date of sale. Refer to Appendix A for complete warranty details.

**NOTE:** If you have an item requiring service, please see the "Warranty and Repairs" page on the PMDX web site (<http://www.pmdx.com>) for return instructions.

In general, the purchaser must pay shipping to send the unit to PMDX. For repairs covered under warranty and with return shipping to a USA address PMDX will ship the repaired unit back to you via ground transportation at our expense. Repairs are normally completed within 10 business days. See Appendix A for our complete warranty details. **Please see the "Warranty and Repairs" page on our web site (<http://www.pmdx.com>) for full details of our repair and shipping policies.**

# PMDX-105 Quad Isolator Board User's Manual

Document Revision: 0.3

## 1.3 Features

The PMDX-105 Quad Isolator Board has the following features:

- Optically isolated inputs support +5V to +24V input signals
- Inputs support PNP-style sensors and PLC outputs (sourcing +5V to +24V)
- Inputs do **not** have pull-ups
- Outputs are "open collector" with optional pull-up (pull-up requires a voltage reference on the "V+" terminal)
- Outputs can be used to drive the inputs on any breakout board that accepts contact closure to ground
- Can drive logic inputs using +5 volts on the "+V" terminal for built-in pull-ups
- Can drive 24 volt PLC inputs using 24 volts on the "+V" terminal for built-in pull-ups (will not work if PLC expects a PNP-style current source on its input)
- Can drive relays up to 50VDC and 200mA
- Clamp style screw terminal strips for inputs and outputs allow use with any breakout board

## 1.4 Updates to this Manual

Check the PMDX web site for revisions or updates to this manual (<http://www.pmdx.com>). The latest revision of this manual is available on the PMDX-105 Quad Isolator Board page (follow the links from the main page).

## 2.0 Installation and Operation

Connectors J1, J2, J3 and J4 provide four pairs of optically-isolated inputs. Connector J5 provides open-collector outputs with an optional pull-up.

The PMDX-105's output signal connector is configured so that the signals line up with either of the PMDX-125's output connector (PMDX-125 connectors J5 and J6). This allows you to place the PMDX-105 next to the PMDX-125 and run wires directly between the two connectors.

Pin Label	Description
+V	power supply for on-board pull-ups, if used (see note below)
"A"	Output signal "A"
"B"	Output signal "B"
"C"	Output signal "C"
"D"	Output signal "D"
Gnd	Ground (signal command and power supply return)

Table 1 –Output Signal Connector Pin-Out (J5)

The PMDX-105 uses solid-state relays to control its outputs. When the input signal is +5V, the corresponding solid-state relay will turn "on" and the output will be connected to the "Gnd" terminal. When the input signal is 0V, the corresponding solid-state relay will turn off and the output will be floating (or pulled up to the "+V" voltage if a voltage reference is connected to the "+V" terminal).

**NOTE:** The PMDX-105's outputs have an optional pull-up on them. To use this pull-up, connect a +5V to +24V reference to the "V+" terminal. Leaving the "V+" terminal unconnected allows the PMDX-105 outputs to behave as normal open-collector outputs.

# PMDX-105 Quad Isolator Board User's Manual

Document Revision: 0.3

## 2.1 Connecting to PMDX-125 Inputs

The PMDX-125 has pull-ups on all of its inputs. Therefore, no connection is needed to the PMDX-105's "+V" terminal. The PMDX-105 outputs will function as "open collector" signals into the PMDX-125.

**Note:**

Similar connections can be made to the PMDX-125 connector J11.

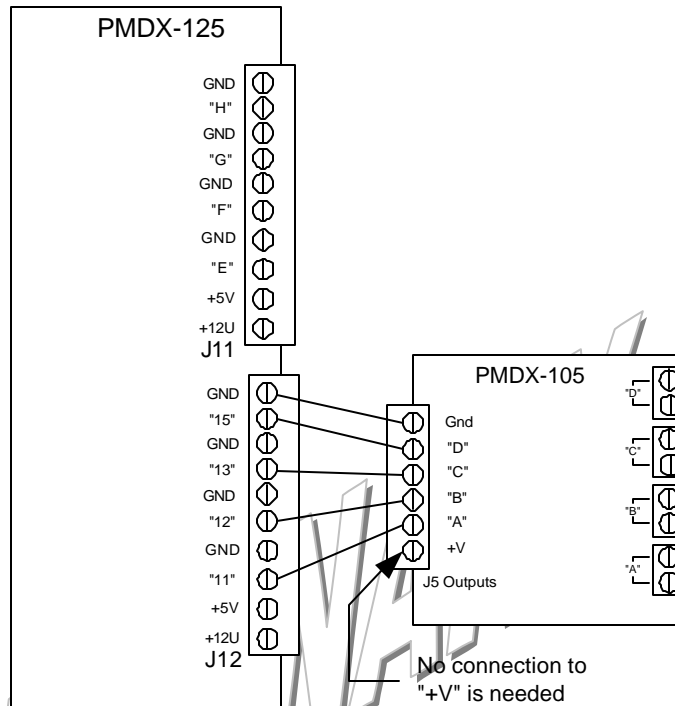

Figure 1 - PMDX-105 to PMDX-125 (J5) Connections

## 2.2 Connecting to PMDX-122 Inputs

The PMDX-122 has pull-ups on all of its inputs. Therefore, no connection is needed to the PMDX-105's "+V" terminal. The PMDX-105 outputs will function as "open collector" signals into the PMDX-122.

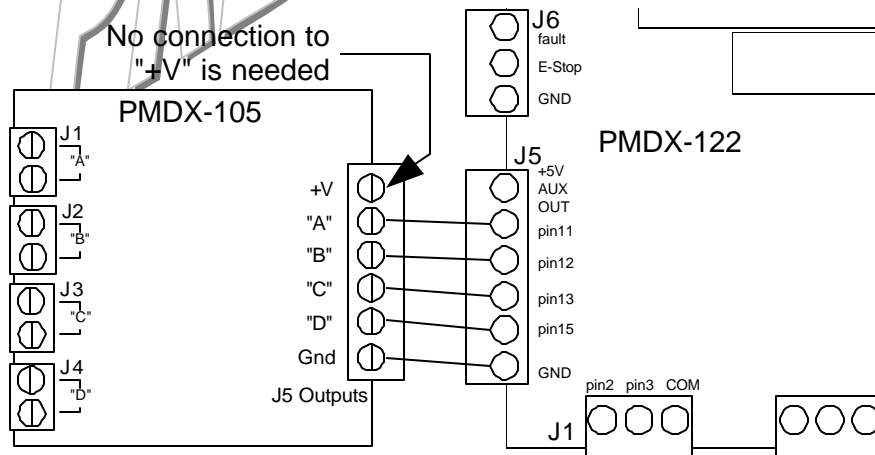

Figure 2 - PMDX-105 to PMDX-122 Connections

# PMDX-105 Quad Isolator Board User's Manual

Document Revision: 0.3

## 2.3 Connecting to PMDX-132 Inputs

The following diagram shows the PMDX-105 connected to a PMDX-132. The PMDX-132 has pull-ups on all of its inputs. Therefore, no connection is needed to the PMDX-105's "V+" terminal. The PMDX-105 outputs will function as "open collector" signals into the PMDX-132.

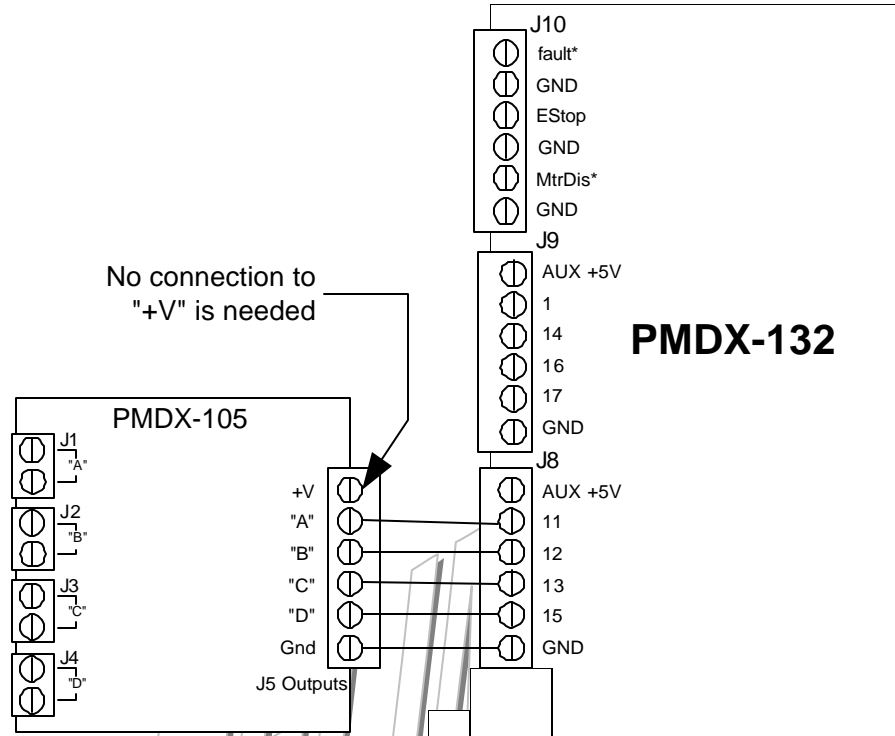

Figure 3 - PMDX-105 to PMDX-132 Connections

## 2.4 Connecting To and Powering PNP Proximity Sensors

The PMDX-105 can be used to interface PNP-style sensors (proximity switches, etc.) to other breakout boards that normally require NPN-style sensors. Figure 4 shows a sample connection between a PNP-style proximity sensor and the PMDX-105. Note that in order for the PMDX-105 to provide isolation between the sensor and the breakout board, the sensor **must** be powered from an isolated power supply.

When using the PMDX-105 along with a PMDX-125 board, the PMDX-125 can provide the isolated power needed for the sensors (as long as the sensors power requirements meet the PMDX-125's specifications, see the *PMDX-125 User's Manual* for more information). In this case, the PMDX-105 does **not** provide any isolation, it just serves as a PNP interface and level translator. The PMDX-125 will still provide optical isolation between the sensors and the parallel port. Figure 5 shows a sample connection diagram for powering the sensors from the PMDX-125.

# PMDX-105 Quad Isolator Board User's Manual

Document Revision: 0.3

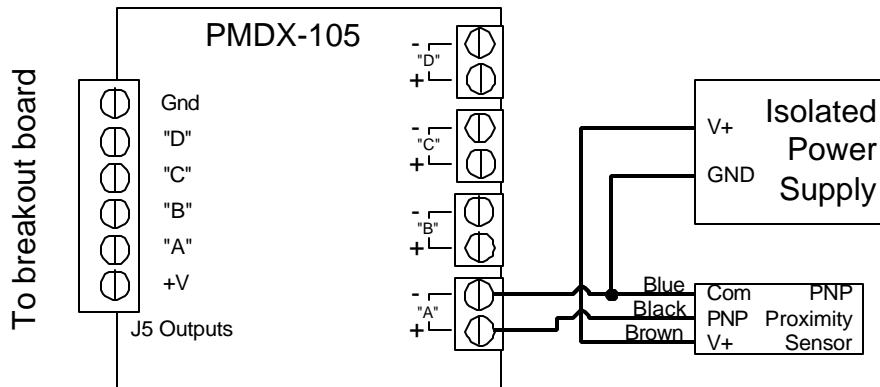

Shows the typical 3-wire color code and power for sensors that require a +10 to +30V supply. Verify your sensor's color code!

Figure 4 - PNP Proximity Sensor to PMDX-105 Connections

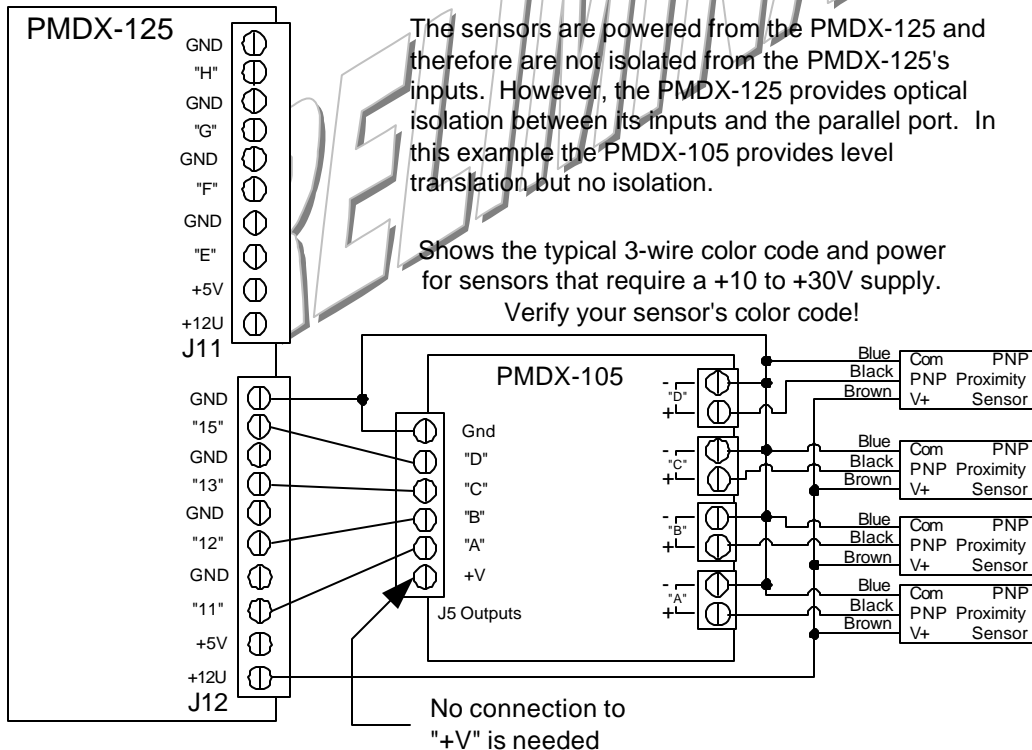

The sensors are powered from the PMDX-125 and therefore are not isolated from the PMDX-125's inputs. However, the PMDX-125 provides optical isolation between its inputs and the parallel port. In this example the PMDX-105 provides level translation but no isolation.

Shows the typical 3-wire color code and power for sensors that require a +10 to +30V supply. Verify your sensor's color code!

Figure 5 - PNP Proximity Sensors to PMDX-105 and Powered by PMDX-125

# PMDX-105 Quad Isolator Board User's Manual

Document Revision: 0.3

## 2.5 Connecting Between Breakout Board Outputs and PLC Inputs

The PMDX-105 works with PLCs (programmable logic controllers) whose inputs accept contact closures to ground. The PMDX-105 then serves to isolate the breakout board's +5V logic outputs from the +24V PLC inputs. The example below is shown using a PMDX-125 connected to a PMDX-105, but any breakout board whose outputs can source 3 mA at +5V will work.

In this configuration, the PMDX-105 inverts the signals. When the breakout board outputs +5V, the PLC input will be pulled to the "COM" terminal. When the breakout board outputs 0V, the PLC input will float.

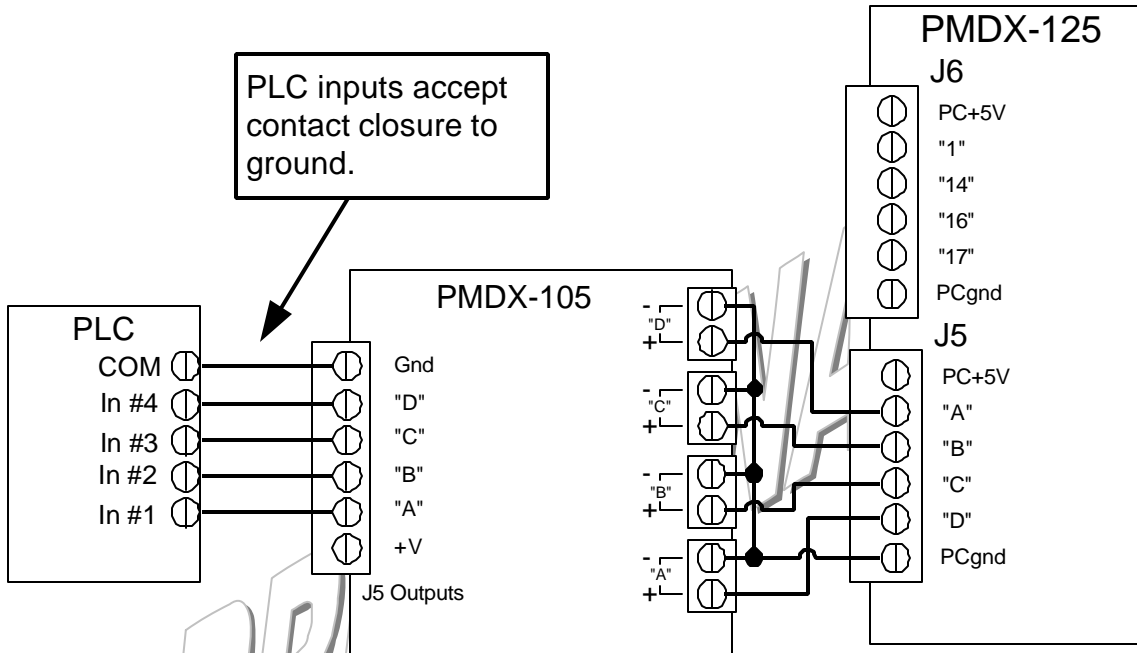

Figure 6 – Breakout Board Outputs to PMDX-105 to PLC Inputs

## 2.6 Connecting to a Generic Breakout Board

TBD

## 3.0 Mechanical Specifications

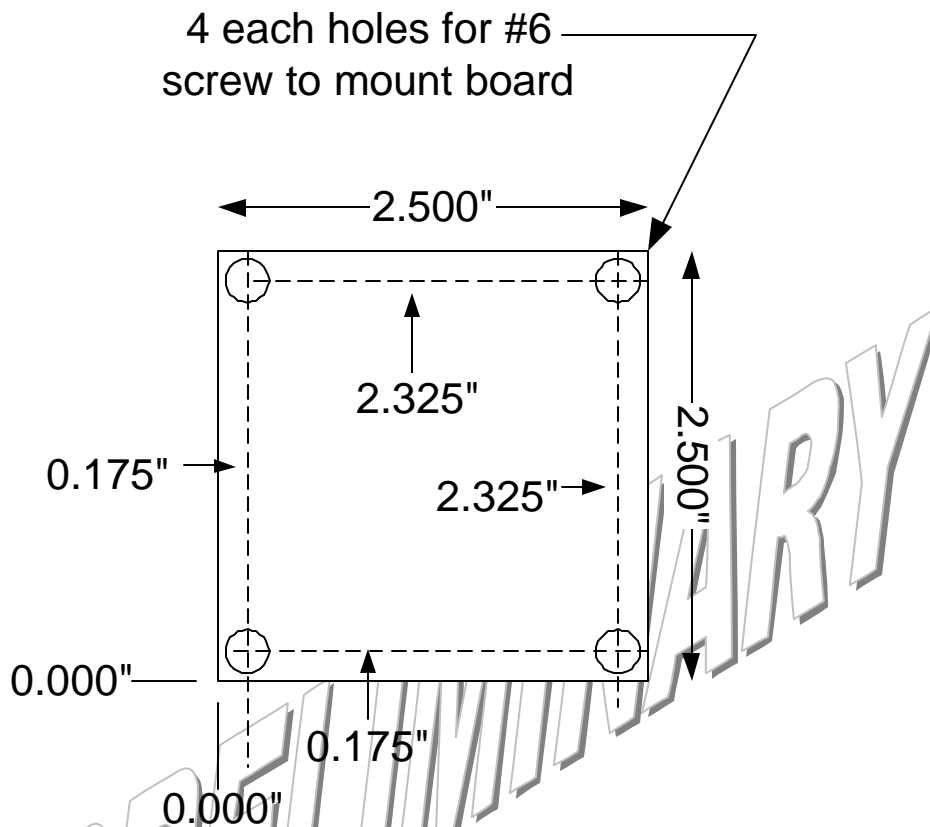

Figure 7 - PMDX-105 Quad Isolator Board Dimensions

**WARNING:** The PMDX-105 Quad Isolator Board should be protected from liquids, dirt, or chips (especially metal chips which can cause shorts) coming in contact with the board.

## 4.0 Electrical and Environmental Specifications

**Power Supply:** Optional +5V to +24VDC input, TBD mA maximum for output pull-up reference

**Isolated Inputs:** +5V to +24V DC  
Input current (sourced by device into the PMDX-105):  
TBD mA minimum (preliminary 3mA at 5V)  
TBD mA maximum (preliminary 20mA at 24V)

**Outputs:** 24V DC maximum  
Output current: Source TBD mA  
Sink: TBD mA

**Environmental:** Temperature: 0° to +55° C  
Relative Humidity: 20% to 80% relative humidity, non-condensing

## Appendix A – Warranty

### Statement

---

Practical Micro Design, Inc. (PMD) warrants that this hardware product is in good working condition, according to its specifications at the time of shipment, for a period of 90 days from the date it was shipped from PMD. Should the product, in PMD's opinion, malfunction within the warranty period, PMD will repair or replace the product without charge. Any replaced parts become the property of PMD. This warranty does not apply to the software component of a product or to a product which has been damaged due to accident, misuse, abuse, improper installation, usage not in accordance with product specifications and instructions, natural or personal disaster or unauthorized alterations, repairs or modifications.

### Limitations

---

All warranties for this product, expressed or implied, are limited to 90 days from the date of purchase and no warranties, expressed or implied, will apply after that period.

All warranties for this product, expressed or implied, shall extend only to the original purchaser.

The liability of Practical Micro Design, Inc. in respect of any defective product will be limited to the repair or replacement of such product. Practical Micro Design, Inc. may use new or equivalent to new replacement parts.

Practical Micro Design, Inc. makes no other representations or warranties as to fitness for purpose, merchantability or otherwise in respect of the product. No other representations, warranties or conditions, shall be implied by statute or otherwise.

In no event shall Practical Micro Design, Inc. be responsible or liable for any damages arising

- (a) from the use of the product;
- (b) from the loss of use of the product;
- (c) from the loss of revenue or profit resulting from the use of the product; or
- (d) as a result of any event, circumstance, action or abuse beyond the control of Practical Micro Design, Inc.

whether such damages be direct, indirect, consequential, special or otherwise and whether such damages are incurred by the person to whom this warranty extends or a third party.