

PMDX-121

Break-Out Board

User's Manual

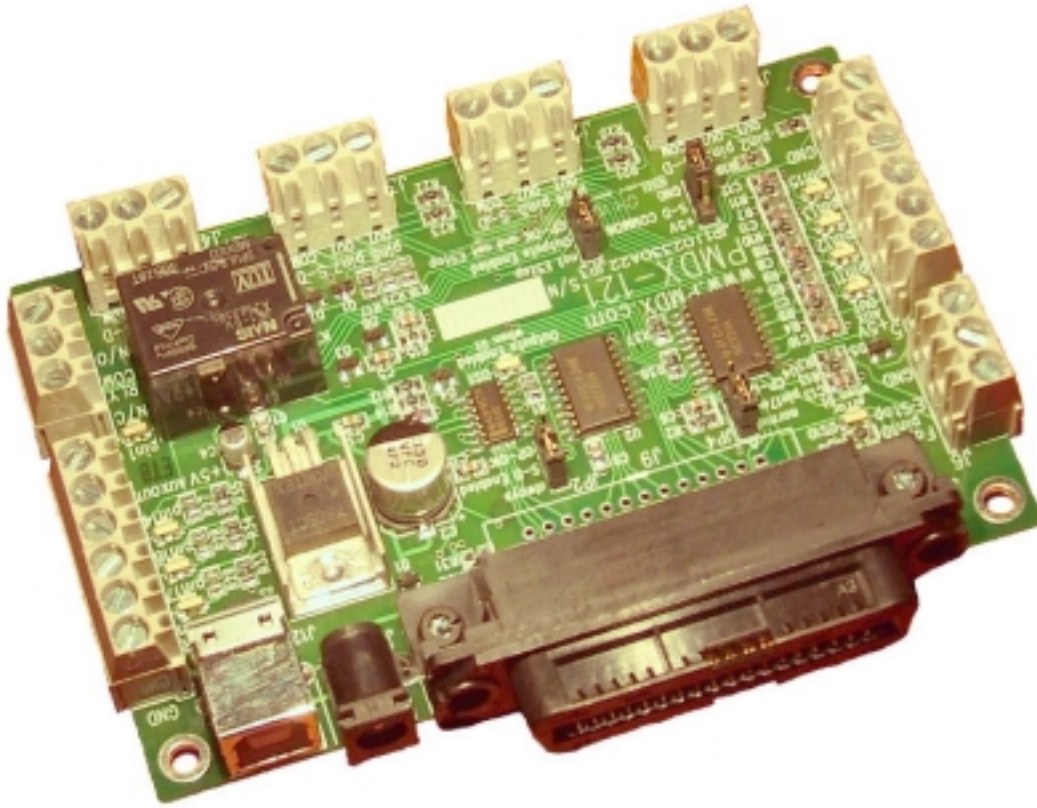

Document Revision: 1.4
Date: 7 September 2004
PCB Revision: PCB-440B
Serial Number: 22594 and above

PMDX
7432 Alban Station Blvd., A105
Springfield, VA 22150-2321 USA

Web: <http://www.pmdx.com>
Phone: +1 (703) 912-4991
FAX: +1 (703) 912-5849

Table of Contents

1.0	Overview	3
1.1	Important Safety Information	3
1.2	Warranty Summary	3
1.3	Features	4
1.4	Updates to this Manual	4
2.0	Connectors	4
2.1	Stepper Motor Connector (J1, J2, J3, and J4)	4
2.2	Status Input Connector (J5)	6
2.3	Fault and E-Stop Connector (J6)	6
2.4	Relay Contact Connector (J7)	6
2.5	Control Output Connector (J8)	7
2.6	PC Parallel Port (J10)	8
2.7	Power Supply (J11)	10
2.8	USB Connector (J12)	10
3.0	Jumpers	10
3.1	S-D Common (JP1)	11
3.2	Step/Direction Output Enable (JP2)	11
3.3	Outputs Enabled Selection (JP3)	11
3.4	Pin 17 Output Source (JP4)	12
4.0	E-Stop Input	12
5.0	Fault Input	13
6.0	Charge Pump (watchdog)	13
7.0	LEDs	13
7.1	"Outputs Enabled" LED (DS1)	13
7.2	"Status Input" LEDs	14
7.3	"Relay State" LED	14
7.4	"Control Output" LEDs	14
7.5	"Error" LED (DS10)	14
	Mechanical Specifications	15
9.0	Electrical and Environmental Specifications	15
	Appendix A – Warranty	16

1.0 Overview

This document describes the configuration and operation of the PMDX-121 Break-Out Board. The PMDX-121 provides an interface between a PC and a multi-axis stepper motor system. This document pertains to the following versions of the PMDX-121:

Circuit Board Revision: PCB-440B (marked on the bottom of the board)

1.1 Important Safety Information

The PMDX-121 is intended for integration by the purchaser into industrial control systems. It is solely the purchaser's responsibility to assure that the system is configured in a manner consistent with applicable safety requirements. Practical Micro Design, Inc. does not control how this board is integrated into the purchaser's system and cannot be responsible for guaranteeing the safety of your system.

The PMDX-121 is not guaranteed to be fail-safe. The system into which the PMDX-121 is installed should provide fail-safe protection and emergency stop capability.

The PMDX-121 contains circuitry that may be connected to dangerous voltages. Care must be taken that user cannot come in contact with these voltages. An enclosure that allows for modest ventilation, but prevents intrusion by operator's hands and foreign objects, especially conductive byproducts of machining operations, should be utilized with this board. Interlock switches on power circuits should remove power when the enclosure is opened.

Automated machine tools, into which the PMDX-121 may be integrated, can cause injury. Precautions should be taken to assure that operators are trained in their proper operation and safety procedures, and that they are protected from moving parts that may be under remote control and may move unexpectedly.

This product may not be used in life support or other critical safety applications.

1.2 Warranty Summary

The PMDX-121 is warranted against failure due to defective parts or workmanship for 90 days from the date of sale. Refer to Appendix A for complete warranty details.

If you have an item requiring service, please see the support page on the PMDX web site (<http://www.pmdx.com>) for return instructions.

The purchaser must pay shipping to return the unit to PMDX. We will ship the repaired unit back to you via ground transportation at our expense. Repairs are normally completed within 10 business days. See Appendix A for our complete warranty details.

1.3 Features

The PMDX-121 has the following features:

PC Parallel Port:

- Buffers signals to/from the PC parallel port
- Allows use of all 8 data bits, 4 control outputs and 5 status inputs
- Centronics cable connector uses standard PC printer cable

Status Inputs:

- 5 each status inputs w/pull-up resistors
- Status signals are buffered
- LED indicators for each input

Relay Contact Outputs:

- Isolated relay with N.O and N.C terminals
- LED indicator for relay state

General Purpose Outputs:

- 3 each general purpose digital outputs
- Outputs are buffered
- LED indicator for each output

Power Supply Input:

- +7 to +12 VDC *or* 6 to 9 VAC input via 2.1mm coaxial jack
- Or +5V via USB connector
- Or alternate +7 to +12 VDC *or* 6 to 9 VAC input via J8 screw terminal connector

Motor Step/Direction:

- 4 axes of step and direction
- Step and direction signals are buffered
- Can supply +5V to motor driver opto-couplers

Special Features:

- Wire clamp screw terminals for all connections to motor drivers, relay and control outputs, and status inputs
- Auxiliary +5 volt supply output

1.4 Updates to this Manual

Check the PMDX web site for revisions or updates to this manual (<http://www.pmdx.com>). The latest revision of this manual is available on the PMDX-121 page (follow the links from the main page).

2.0 Connectors

The PMDX-121 contains the following connectors. Refer to the following sections for details on the pin-outs for each connector. For all connectors, pin "1" is the pin closest to the reference designator (i.e. J1 pin 1 is the pin closest to the "J1" text on the circuit board). In addition, all connectors have square pads on pin 1 (look on the bottom of the circuit board).

<i>Connector</i>	<i>Description</i>
J1, J2, J3, J4	Step and Direction outputs
J5	Status Input Signals
J6	Fault and E-Stop inputs
J7	Relay contact outputs
J8	Control Outputs
J10	Centronics 36-pin PC Parallel Port
J11	DC Power via 2.1mm coax connector
J12	USB Connector (used for power only)

Table 1 - Summary of PMDX-121 Connectors

2.1 Stepper Motor Connector (J1, J2, J3, and J4)

Connectors J1 through J4 contain buffered versions of the PC parallel port "data bus" signals, which are normally used as stepper motor "step" and "direction" outputs. The PMDX-121 buffers each of these signals. Depending on the setting of jumper JP2, the buffer may have its outputs "tri-stated". See section 3.2, *Step/Direction Output Enable*, for more information.

When the step and direction outputs are disabled by E-Stop or "charge pump" failure, the PMDX-121 provides a 10K ohm resistor between each step and direction signal and the "S-D COM" signal. This provides a known logic state when the output buffers are disabled.

The PMDX-121 does not define which signal is "step" and which is "direction". In fact, the PMDX-121 allows these signals to be used for any purpose. Their function depends on the software used to generate the signals on the PC. The output connectors are labeled to denote which pin on the PC's parallel port that is associated with each connector pin.

<i>Pin Number</i>	<i>Label</i>	<i>Description</i>
1	Pin 2 OUT	Buffered signal from pin 2 of the PC parallel port's 25-pin "D" connector (parallel port signal name "D0")
2	Pin 3 OUT	Buffered signal from pin 3 of the PC parallel port's 25-pin "D" connector (parallel port signal name "D1")
3	S-D COM	Step & Direction common voltage reference, same for all four connectors (see section 3.1 for reference source)

Table 2 –Stepper Motor Connector Pin-Out (J1)

<i>Pin Number</i>	<i>Label</i>	<i>Description</i>
1	Pin 4 OUT	Buffered signal from pin 4 of the PC parallel port's 25-pin "D" connector (parallel port signal name "D2")
2	Pin 5 OUT	Buffered signal from pin 5 of the PC parallel port's 25-pin "D" connector (parallel port signal name "D3")
3	S-D COM	Step & Direction common voltage reference, same for all four connectors (see section 3.1 for reference source)

Table 3 –Stepper Motor Connector Pin-Out (J2)

<i>Pin Number</i>	<i>Label</i>	<i>Description</i>
1	Pin 6 OUT	Buffered signal from pin 6 of the PC parallel port's 25-pin "D" connector (parallel port signal name "D4")
2	Pin 7 OUT	Buffered signal from pin 7 of the PC parallel port's 25-pin "D" connector (parallel port signal name "D5")
3	S-D COM	Step & Direction common voltage reference, same for all four connectors (see section 3.1 for reference source)

Table 4 –Stepper Motor Connector Pin-Out (J3)

<i>Pin Number</i>	<i>Label</i>	<i>Description</i>
1	Pin 8 OUT	Buffered signal from pin 8 of the PC parallel port's 25-pin "D" connector (parallel port signal name "D6")
2	Pin 9 OUT	Buffered signal from pin 9 of the PC parallel port's 25-pin "D" connector (parallel port signal name "D7")
3	S-D COM	Step & Direction common voltage reference, same for all four connectors (see section 3.1 for reference source)

Table 5 –Stepper Motor Connector Pin-Out (J4)

2.2 Status Input Connector (J5)

The PMDX-121 supports four general-purpose status input signals. These inputs have a low-pass (RC) filter to remove high-frequency noise. Each signal also has a pull-up and an LED that is "on" when the input signal is driven low. The input signals are buffered (but not inverted) before being passed to the PC parallel port.

The fifth status input on the PC parallel port is connected to the "Fault" and "E-Stop" circuitry. See sections 4.0, *E-Stop Input* and 5.0, *Fault Input*, for more information.

Pin Number	Label	Description
1	+5V Aux Out	Auxiliary +5V output for external sensor power
2	Pin 11	Status input, buffered, to PC parallel port pin 11 (Busy)
3	Pin 12	Status input, buffered, to PC parallel port pin 12 (Paper End)
4	Pin 13	Status input, buffered, to PC parallel port pin 13 (Select Out)
5	Pin 15	Status input, buffered, to PC parallel port pin 15 (~Error)
6	GND	Ground connection

Table 6 – Status Input Connector Pin-Out (J5)

NOTE – Due to logic inside the PC, some status inputs are inverted. This means that a logic "high" output from the PMDX-121 to the PC's parallel port is read as a "0" in the status register. Please refer to technical documentation on the PC parallel port, or your control software, for more information.

2.3 Fault and E-Stop Connector (J6)

J6 provides the "Fault" and "E-Stop" input signals to the PMDX-121. Refer to sections 4.0, *E-Stop Input* and 5.0, *Fault Input*, for more information on using these signals.

Pin Number	Label	Description
1	Fault*	Fault input (active low, i.e. "ground" to signal a fault)
2	E-Stop	Emergency Stop input (active high, i.e. "open" to signal E-Stop). You <i>must</i> provide a ground via the E-Stop switch chain or a direct jumper in order to enable the outputs on the PMDX-121 board.
3	GND	Ground connection

Table 7 – E-Stop and Fault Connector Pin-Out (J6)

2.4 Relay Contact Connector (J7)

The PMDX-121 uses the PC parallel port control signal "~Strobe" (pin 1 on the PC's 25-pin "D" connector) to control the on-board relay. The relay provides both a "normally open" and a "normally closed" connection. There is an LED near J7 to indicate the relay status. This LED is "on" when the relay is energized.

The relay will be forced to the "de-energized" state, regardless of the state of the "~Strobe" signal, under the following circumstances:

- The "E-Stop" signal is asserted (see section 4.0, *E-Stop Input*)
- The "~Fault" signal is asserted (see section 5.0, *Fault Input*)
- or optionally, depending on the setting of jumper when the charge pump JP3, a failure in the charge pump circuit (see section 3.3 for information on the jumper setting, and section 6.0 for information on the charge pump)

<i>Pin Number</i>	<i>Label</i>	<i>Description</i>
1	N/O	Normally Open relay contact (i.e. open when relay is not energized)
2	RLY COM	Relay common terminal
3	N/C	Normally Closed relay contact (i.e. closed when relay is not energized)

Table 8 – Relay Contact Output Connector Pin-Out (J7)

NOTE – Due to logic inside the PC, the “~Strobe” control output is inverted. This means that writing a “1” to a bit in the control register results in a logic “low” at the 25-pin D connector. In order to energize the relay, a “0” must be written to the parallel port control register. Please refer to technical documentation on the PC parallel port, or your control software, for more information.

2.5 Control Output Connector (J8)

The PMDX-121 supports three general-purpose control outputs, as shown in Table 9 below. The fourth PC parallel port control signal (~Strobe) is dedicated to the PMDX-121’s on-board relay (see section 2.4). The control outputs are buffered, and each output has an LED that in “on” when the output signal is driven high.

The control output on pin 4 (labeled “Pin 17”) can be driven by one of two sources, based on the setting of jumper JP4. See section 3.4, **Pin 17 Output Source**, for more information.

The control signal output buffer will be disabled under the following circumstances:

- The “E-Stop” signal is asserted (see section 4.0, **E-Stop Input**)
- The “~Fault” signal is asserted (see section 5.0, **Fault Input**)
- or optionally, depending on the setting of jumper when the charge pump JP3, a failure in the charge pump circuit (see section 3.3 for information on the jumper setting, and section 6.0 for information on the charge pump)

The PMDX-121 provides 10K ohm pull-down resistors on all of the control output signals. When the output buffer is disabled, these pull-down resistors provide a known logic level (low) to the external devices. Note that this is a fairly weak pull-down, and can be overridden externally with a stronger pull-up resistor if required.

WARNING – When using the “Aux. Power In” on J8, make sure that no power source is connected to J11.

<i>Pin Number</i>	<i>Label</i>	<i>Description</i>
1	+5V Aux Out	Auxiliary +5V output
2	Pin 14	Control output from PC parallel port pin 14 (Auto Feed)
3	Pin 16	Control output from PC parallel port pin 16 (~Init)
4	Pin 17	Control output from PC parallel port pin 17 (~Select In) <i>or</i> logic high, depending on the setting of jumper JP4 (see section 3.4)
5	PWR Alt In	Alternate power input terminal
6	GND	Ground connection

Table 9 – Control Output Connector Pin-Out (J8)

NOTE – Due to logic inside the PC, some control outputs are inverted. This means that that writing a “1” to a bit in the control register may result in a logic “low” at the 25-pin D connector. Please refer to technical documentation on the PC parallel port, or your control software, for more information.

2.6 PC Parallel Port (J10)

The PMDX-121 provides a Centronics-style connector for connections to a PC's parallel port. This allows the use of a standard PC printer cable.

NOTE – Some printer cables do not have good signal shielding. Some cables also omit some of the status or control signals (such as “Auto Feed” and “Select Out”, 25-pin D connector pin numbers 14 and 13, respectively). We recommend using cables that are listed as IEEE-1284 compliant.

Pin Numbers		PC Signal Name	Direction (relative to PC)	PMDX-121 Signal	Comment
PC (note 1)	J10 (note 3)				
1	1	~Strobe (note 4)	out	Relay Control	Relay energized w/logic high at the PC pin (see section 2.4)
2	2	Data 0	out	Step/Dir input	Step and direction signals are buffered and then connected to the PMDX-121's step & direction output connectors (see section 2.1)
3	3	Data 1	out	Step/Dir input	
4	4	Data 2	out	Step/Dir input	
5	5	Data 3	out	Step/Dir input	
6	6	Data 4	out	Step/Dir input	
7	7	Data 5	out	Step/Dir input	
8	8	Data 6	out	Step/Dir input	
9	9	Data 7	out	Step/Dir input	
10	10	~Ack (note 4)	in	E-Stop & Fault status	Driven high when E-Stop or Fault input is active
11	11	Busy	in	Status Input	
12	12	Paper End	in	Status Input	
13	13	Select Out (note 2)	in	Status Input	
14	14	~Auto Feed (note 4)	out	Control Output	
15	32	~Error (note 4)	in	Status Input	
16	31	~Init (note 4)	out	Control Output	
17	36	~Select In (note 2 & 4)	out	Control Output	
N/A	18	N/A	N/A	No connect	Centronics connector only, no connection on the PC's 25-pin "D" connector or the PMDX-121
18 – 25	19-30, 33	Ground		Ground	

Table 10- PC Parallel Port Connectors (J10 and J9)

NOTE 1 – The PC Pin number column lists the pin numbers as they would appear on the PC's 25-pin D connector when using a standard printer cable.

NOTE 2 – The "~Select In" and "Select Out" signals are named relative to the printer's point of view. That is why the "~Select In" is an **output** from the PC, and "Select Out" in an **input**.

NOTE 3 – J10 is the Centronics 36-pin connector on the PMDX-121.

NOTE 4 – The "~" character at the beginning of some of the signal names indicates a signal that is "active low" (measured at the PC's 25-pin D connector) **when connected to a printer**. The PMDX-121 **does not** necessarily use the polarity implied by the signal names. Refer to sections 2.2 and 2.5 for information on PMDX-121 signal polarities.

The following web sites provide information regarding the PC's parallel port, including pin-outs, signal names and useful data for software control of the parallel port:

- IBM PC Parallel Port FAQ and tutorial
<http://www.pmdx.com/Resources/parallel-port.html>
 and
<http://et.nmsu.edu/~etti/fall96/computer/printer/printer.html>
- General information and lots of links
<http://www.lvr.com/parport.htm>
- If the previous links do not work, go to <http://www.pmdx.com> (our main web page), click on the PMDX-120 link, then look for the links to parallel port information pages)

Note that these web links were accurate as of the printing date of this manual. While we expect that these two sites will remain available at these addresses, it *is* possible that they will move or disappear.

2.7 Power Supply (J11)

Connector J11 is used to provide +7 to +12 VDC *or* 6 to 9 VAC power to the PMDX-121. This connector is a standard 2.1mm diameter coaxial power connector that is compatible with many wall-mounted power packs.

WARNING – When using J11, make sure that no power source is connected to J8 pin 5 (Aux. Power In). See section 2.5 for more information. Also, the USB connector should not be connected, though no damage should occur.

<i>Pin</i>	<i>Description</i>
Center Pin	Positive voltage (or AC voltage)
Sleeve	Ground

Table 11 – Power Supply Connector Pin-Out (J11)

2.8 USB Connector (J12)

The USB connector can be used as an alternate power source for the PMDX-121. The PMDX-121 draws a maximum of 200mA from this connector. See section 9.0, *Electrical and Environmental Specifications*, for information regarding USB hub requirements. When using the USB as a power source, there should not be any power source connected to J11 or to J8 pin 5. The PMDX-121 has series diode protection on the USB power supply lines, so no damage to the USB host or the PMDX-121 should occur if another power source is connected along with the USB. It is better to avoid this situation in the first place, however.

NOTE – The PMDX-121 is *not* a USB device. It does not send or receive data or control information to the PC. There are no device drivers that need to be installed on the PC. The PMDX-121 uses the USB connector solely as an alternate power source.

3.0 Jumpers

The PMDX-121 contains four 3-pin jumpers that determine various aspects of its behavior. Each jumper has silk screen labels that describe the function of the jumper, and each possible setting. Each jumper should have a shorting block installed either between pins 1 and 2, or between pins 2 and 3.

3.1 S-D Common (JP1)

The step and direction connectors provide a "common" voltage reference for all four step and direction output connectors (i.e. the same reference voltage appears on all four connectors). See section 2.1 for more information on the step and direction output connectors. Jumper JP1 (labeled "S-D Common" on the circuit board) determines this voltage reference as shown in the following table:

Setting	Label	Description
1 to 2	+5V	Supplies +5V to the common terminals. This configuration is commonly used when the motor drivers have optically isolated inputs and expect a "pull-down" or "open-collector" drive signal. In this case, the PMDX-121 supplies the +5V power to the opto-couplers. See also the note below.
2 to 3	GND	Connects ground to the common terminals. This setting would typically be used with motor drivers that have non-isolated, TTL logic style inputs, but also has enough drive for most opto-couplers.

Table 12 – Step/Direction Common Jumper Settings (JP1)

NOTE – Changing the common reference from "+5V" to "Gnd" (via jumper JP1) when feeding optically isolated driver inputs will have the effect of inverting the step and direction signals.

WARNING – When connecting to non-isolated motor driver inputs, do not connect the PMDX-121's "+5V" reference to ground on the motor driver module. Doing so may damage the buffer on the PMDX-121, the inputs to the motor driver, and possibly the PC's parallel port.

3.2 Step/Direction Output Enable (JP2)

The PMDX-121 allows the "E-Stop", "Fault" and charge pump circuits to disable the step and direction output signals. Jumper JP2, along with JP3, determine if and when the step and direction outputs will be disabled. Jumper JP2 is labeled "S-D Enable" on the circuit board.

Refer to section 2.1, *Stepper Motor Connector*, for information on the behavior of the step and direction outputs when they are disabled.

Setting	Label	Description
1 to 2	always	The step and direction outputs are always enabled (i.e. ignore the "E-Stop", "~Fault" and charge pump circuits)
2 to 3	CP-OK	Step and direction outputs are enabled as long as the "Outputs Enabled" LED is "on". Note that this setting not only pertains to the charge pump (the "CP" in "CP-OK"), but also to the emergency stop and fault inputs. See sections 3.3, <i>Outputs Enabled Selection</i> , and 7.1, <i>"Outputs Enabled" LED</i> , for more information).

Table 13 – Step/Direction Output Enable Jumper Settings (JP2)

3.3 Outputs Enabled Selection (JP3)

Jumper JP3 is labeled "Outputs Enabled" and selects whether or not the charge pump circuit can disable the output buffers, as well as when the "Outputs enabled when lit" LED in "on".

Setting	Label	Description
1 to 2	not EStop	Outputs are enabled (and LED is "on") when the E-Stop (and ~Fault) signals are NOT asserted (the charge pump circuit is ignored)
2 to 3	CP-OK and not EStop	Outputs are enabled (and LED is "on") when the charge pump circuit is OK (i.e. the charge pump circuit is "enabled") and the E-Stop and ~Fault signals are NOT asserted

Table 14 –Outputs Enabled Jumper Settings (JP3)

3.4 Pin 17 Output Source (JP4)

Jumper JP4 is labeled "pin 17 out" and selects which circuits are driven by pin 17 on the PC parallel port (~Select In).

Setting	Label	Description
1 to 2	normal	Pin 17 from the PC parallel port drives the "pin 17" control output as well as the charge pump circuitry
2 to 3	CP-OK	Pin 17 from the PC parallel port drives only the charge pump circuitry. The "pin 17" control output is driven "high" or floats low based on the state of the E-Stop and Fault inputs, and the "charge pump" circuit. See section 2.5 for more information.

Table 15 –Outputs Enabled Jumper Settings (JP3)

4.0 E-Stop Input

The "E-Stop" input provides an interface for external "emergency stop" circuits. This signal is "active high", meaning that a logic "high" tells the system to stop, and a logic low means "all is OK".

The E-Stop input is designed to be connected to an external "normally closed" switch (or group of switches all wired in series). The external switch(es) should be wired between the E-Stop pin and ground, such that the switch contacts open to signal an emergency stop condition. The PMDX-121 provides a 2.2K ohm pull-up resistor on the E-Stop input. This means that the external emergency stop circuit must be capable of sinking 2.7 mA of current when the switch contacts are "closed" (this should not be a problem for mechanical switches).

The "E-Stop" and "Fault" inputs are combined (logic "OR") to drive the "~Ack" status signal to the PC's parallel port.

NOTE – The E-Stop signal **must** be grounded (driven low) in order for the output buffers to be enabled and for the "~Ack" status signal to the PC parallel port to go low.

When either (or both) the E-Stop (active high) or ~Fault (active low) inputs are asserted, the following actions take place:

- The ACK bit in the PC's status register reads as a "1"
- The LED labeled "error when lit" (reference designator DS10, near J6) is "on".
- The LED labeled "Outputs Enabled when lit" (reference designator DS1, near the center of the board) is "off"
- The status outputs are tri-stated with a weak (10K ohm) pull-down
- The relay is de-energized
- The step and direction outputs **may** be tri-stated with weak (10K ohm) pull-down, depending on the setting of JP2 (see section 3.2)

5.0 Fault Input

The "Fault" input provides an interface for external fault detection circuits, such as the fault signals from the PMDX-150 stepper motor drivers. This signal is "active low", meaning that a logic "low" indicates a fault condition, and a logic high means "all is OK".

The fault input is designed to be connected to an external "wired-or" configuration of open-collector status signals. All of the open-collector fault signals should be tied together and connected to the fault input. The PMDX-121 provides a 10K ohm pull-up resistor on the fault input. This means the open-collector drivers must be able to sink approximately 0.5 mA of current.

The "E-Stop" and "Fault" inputs are combined (logic "OR") to drive the "~Ack" status signal to the PC's parallel port. Refer to section 4.0, *E-Stop Input*, for a list of actions that take place when the "Fault" input is drive low.

NOTE – The fault signal *must* be allowed to float high (or be driven high) in order for the output buffers to be enabled and for the "~Ack" status signal to the PC parallel port to go low.

6.0 Charge Pump (watchdog)

The charge pump circuit (also called a watchdog circuit) is designed to disable the PMDX-121 outputs when the software running on the PC stops working properly. It does this by monitoring pin 17 on the PC parallel port (the "~Select In" signal). When this signal is toggling between high and low, the charge pump is "OK" and enables the output buffers. When the signal stops toggling, the PMDX-121 disables the output buffers.

This charge pump circuit is designed to work with the Mach2 CNC software. However, any software that can toggle pin 17 on the PC parallel port can make use of this feature. If your software does not support this feature, configure the jumpers to disable the charge pump circuit.

Jumper JP3 determines whether the output from the charge pump is used to enable and disable the output buffers. See section 3.3 for more information. Furthermore, jumper JP2 determines whether the step and direction outputs are ever disabled. See section 3.2 for more information.

NOTE – The state of the charge pump signal is *not* reflected in the E-Stop and Fault status that is output on the "~Ack" signal to the PC (pin 10 on the parallel port). This is to prevent "lock up" of the software. Mach2 requires that the Emergency Stop signal (~Ack) *not* be asserted before it will start generating the "charge pump" signal.

7.0 LEDs

The PMDX-121 provides LEDs to show the state of many of the status and control signals. These LEDs are described in the following sections.

7.1 "Outputs Enabled" LED (DS1)

The "Outputs Enabled" LED is located near the center of the circuit board, just above the serial number block, and is labeled "Outputs Enabled when lit". This LED is "on" when the control output buffers are enabled. Also, depending on the settings of jumpers JP2, the step and direction outputs are enabled when this LED is "on" (see section 3.2 for more information).

The "Outputs Enabled" LED is "on" when all of the following conditions are met:

- The "E-Stop" input is driven low (see section 4.0)
- The "~Fault" input is driven (or allowed to float) high (see section 5.0)
- optionally, the charge pump circuit is "OK" (depends on the setting of JP3, see section 3.3)

7.2 "Status Input" LEDs

The "Status Input" LEDs are located next to connector J5, just above each of the pin number labels ("pin 11", "pin 12", etc.). Each LED is "on" when the corresponding input signal is driven low.

7.3 "Relay State" LED

The "Relay State" LED is located between the relay and connector J7, and is labeled "pin 1 outputs" (since it is driven by the "~Strobe" signal, which is pin 1 on the PC's parallel port). The LED is "on" when the relay is energized. See section 2.4 for more information.

7.4 "Control Output" LEDs

The "Control Output" LEDs are located next to connector J8, just above each of the pin number labels ("pin 14", "pin 16", and "pin 17"). Each LED is "on" when the corresponding output signal is driven high.

7.5 "Error" LED (DS10)

The "Error" LED is located next to connector J6, and is labeled "error when lit". The LED indicates the state of the "~Ack" signal to the PC and is "on" to indicate an error condition. Error conditions are caused by either the "Fault" input or the "E-Stop" inputs. See sections 4.0, *E-Stop Input*, and 5.0, *Fault Input*, for more information on these signals.

8.0 Mechanical Specifications

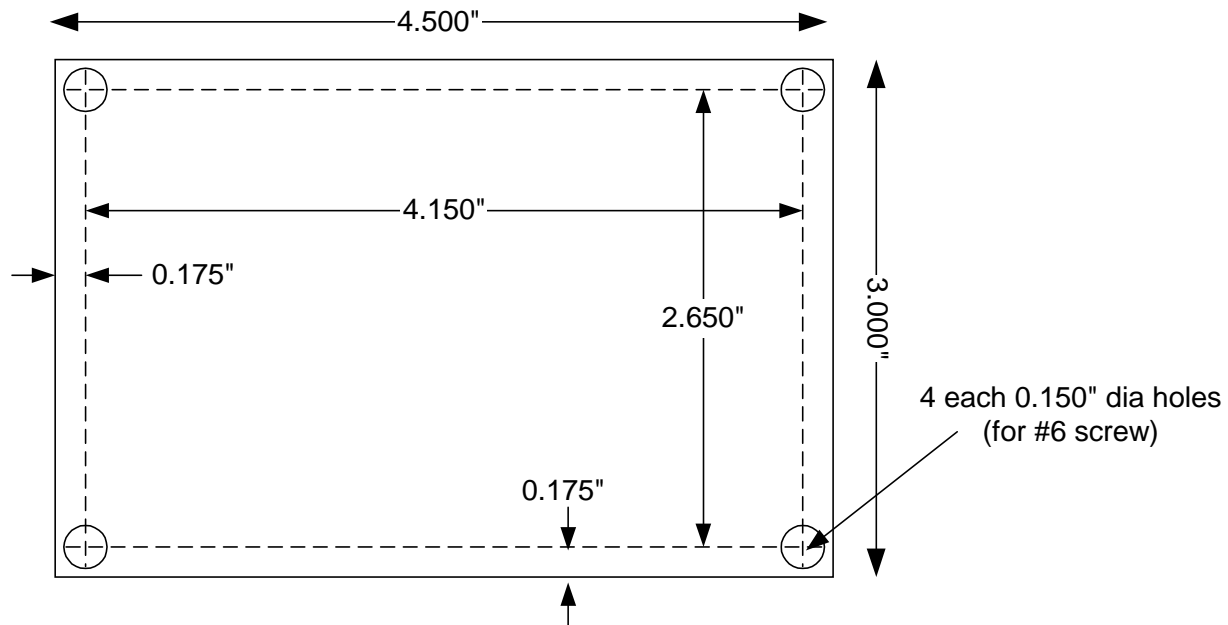

Figure 1 - PMDX-121 Dimensions and Mounting Holes

WARNING: The PMDX-121 should be protected from liquids, dirt, or chips (especially metal chips which can cause shorts) coming in contact with the board.

9.0 Electrical and Environmental Specifications

Main Power: +7 to +12 VDC *or* 6 to 9 VAC input, 200 mA maximum

USB Power: +5V DC, 200 mA maximum (optional power source as alternate to main DC power)

Note: 100mA is the USB standard current limit provided to "un-initialized USB devices" by a USB hub. Therefore, you should only connect the PMDX-121 to self-powered hubs or directly to a PC's USB port. Bus-powered USB hubs may not be able to provide more than 100mA.

Status Inputs: Min. input "high": 2.0V (referenced to the "Gnd" terminal)
 Max. input "low": 0.8V (referenced to the "Gnd" terminal)

Control Outputs: Min. output "high": 3.7V (referenced to the "Gnd" terminal, sourcing up to 16 mA per output)
 Max. output "low": 0.4V (referenced to the "Gnd" terminal, sinking up to 16 mA per output)

Environmental: Temperature: 0° to +55° C
 Relative Humidity: 20% to 80% relative humidity, non-condensing

Appendix A – Warranty

Statement

Practical Micro Design, Inc. (PMD) warrants that this hardware product is in good working condition, according to its specifications at the time of shipment, for a period of 90 days from the date it was shipped from PMD. Should the product, in PMD's opinion, malfunction within the warranty period, PMD will repair or replace the product without charge. Any replaced parts become the property of PMD. This warranty does not apply to the software component of a product or to a product which has been damaged due to accident, misuse, abuse, improper installation, usage not in accordance with product specifications and instructions, natural or personal disaster or unauthorized alterations, repairs or modifications.

Limitations

All warranties for this product, expressed or implied, are limited to 90 days from the date of purchase and no warranties, expressed or implied, will apply after that period.

All warranties for this product, expressed or implied, shall extend only to the original purchaser.

The liability of Practical Micro Design, Inc. in respect of any defective product will be limited to the repair or replacement of such product. Practical Micro Design, Inc. may use new or equivalent to new replacement parts.

Practical Micro Design, Inc. makes no other representations or warranties as to fitness for purpose, merchantability or otherwise in respect of the product. No other representations, warranties or conditions, shall be implied by statute or otherwise.

In no event shall Practical Micro Design, Inc. be responsible or liable for any damages arising

- (a) from the use of the product;
- (b) from the loss of use of the product;
- (c) from the loss of revenue or profit resulting from the use of the product; or
- (d) as a result of any event, circumstance, action or abuse beyond the control of Practical Micro Design, Inc.

whether such damages be direct, indirect, consequential, special or otherwise and whether such damages are incurred by the person to whom this warranty extends or a third party.